

## CHAPTER 16

# STRUCTURAL DESIGN

### SECTION 1601 GENERAL

**1601.1 Scope.** The provisions of this chapter shall govern the structural design of buildings, structures and portions thereof regulated by this code.

### SECTION 1602 DEFINITIONS

**1602.1 Definitions.** The following words and terms shall, for the purposes of this chapter, have the meanings shown herein.

**ALLOWABLE STRESS DESIGN.** A method of proportioning structural members, such that elastically computed stresses produced in the members by nominal loads do not exceed specified allowable stresses (also called “working stress design”).

**BALCONY, EXTERIOR.** An exterior floor projecting from and supported by a structure without additional independent supports.

**BASE SHEAR.** Total design lateral force or shear at the base.

#### **BASIC SEISMIC-FORCE-RESISTING SYSTEMS.**

**Bearing wall system.** A structural system without a complete vertical load-carrying space frame. Bearing walls or bracing elements provide support for substantial vertical loads. Seismic lateral force resistance is provided by shear walls or braced frames.

**Building frame system.** A structural system with an essentially complete space frame providing support for vertical loads. Seismic lateral force resistance is provided by shear walls or braced frames.

**Dual system.** A structural system with an essentially complete space frame providing support for vertical loads. Seismic lateral force resistance is provided by a moment frame and shear walls or braced frames.

**Inverted pendulum system.** A structure with a large portion of its mass concentrated at the top; therefore, having essentially one degree of freedom in horizontal translation. Seismic lateral force resistance is provided by the columns acting as cantilevers.

**Moment-resisting frame system.** A structural system with an essentially complete space frame providing support for vertical loads. Seismic lateral force resistance is provided by moment frames.

**Shear wall-frame interactive system.** A structural system which uses combinations of shear walls and frames designed to resist seismic lateral forces in proportion to their rigidities, considering interaction between shear walls and frames on all levels. Support of vertical loads is provided by the same shear walls and frames.

**BOUNDARY MEMBERS.** Strengthened portions along shear wall and diaphragm edges (also called “boundary elements”).

**Boundary element.** In light-frame construction, diaphragms and shear wall boundary members to which sheathing transfers forces. Boundary elements include chords and drag struts at diaphragm and shear wall perimeters, interior openings, discontinuities and reentrant corners.

**CANTILEVERED COLUMN SYSTEM.** A structural system relying on column elements that cantilever from a fixed base and have minimal rotational resistance capacity at the top with lateral forces applied essentially at the top and are used for lateral resistance.

**COLLECTOR ELEMENTS.** Members that serve to transfer forces between floor diaphragms and members of the lateral-force-resisting system.

**CONFINED REGION.** The portion of a reinforced concrete component in which the concrete is confined by closely spaced special transverse reinforcement restraining the concrete in directions perpendicular to the applied stress.

**DEAD LOADS.** The weight of materials of construction incorporated into the building, including but not limited to walls, floors, roofs, ceilings, stairways, built-in partitions, finishes, cladding and other similarly incorporated architectural and structural items, and fixed service equipment, including the weight of cranes. All dead loads are considered permanent loads.

**DECK.** An exterior floor supported on at least two opposing sides by an adjacent structure, and/or posts, piers or other independent supports.

**DEFORMABILITY.** The ratio of the ultimate deformation to the limit deformation.

**High deformability element.** An element whose deformability is not less than 3.5 when subjected to four fully reversed cycles at the limit deformation.

**Limited deformability element.** An element that is neither a low deformability or a high deformability element.

**Low deformability element.** An element whose deformability is 1.5 or less.

#### **DEFORMATION.**

**Limit deformation.** Two times the initial deformation that occurs at a load equal to 40 percent of the maximum strength.

**Ultimate deformation.** The deformation at which failure occurs and which shall be deemed to occur if the sustainable load reduces to 80 percent or less of the maximum strength.

**DESIGN STRENGTH.** The product of the nominal strength and a resistance factor (or strength reduction factor).

**DIAPHRAGM.** A horizontal or sloped system acting to transmit lateral forces to the vertical-resisting elements. When the term “diaphragm” is used, it shall include horizontal bracing systems.

**Diaphragm, blocked.** In light-frame construction, a diaphragm in which all sheathing edges not occurring on a framing member are supported on and fastened to blocking.

**Diaphragm boundary.** In light-frame construction, a location where shear is transferred into or out of the diaphragm sheathing. Transfer is either to a boundary element or to another force-resisting element.

**Diaphragm chord.** A diaphragm boundary element perpendicular to the applied load that is assumed to take axial stresses due to the diaphragm moment.

**Diaphragm, flexible.** A diaphragm is flexible for the purpose of distribution of story shear and torsional moment when the computed maximum in-plane deflection of the diaphragm itself under lateral load is more than two times the average drift of adjoining vertical elements of the lateral-force-resisting system of the associated story under equivalent tributary lateral load (see Section 1617.5.3).

**Diaphragm, rigid.** A diaphragm is rigid for the purpose of distribution of story shear and torsional moment when the lateral deformation of the diaphragm is less than or equal to two times the average story drift.

**DURATION OF LOAD.** The period of continuous application of a given load, or the aggregate of periods of intermittent applications of the same load.

#### ELEMENT.

**Ductile element.** An element capable of sustaining large cyclic deformations beyond the attainment of its nominal strength without any significant loss of strength.

**Limited ductile element.** An element that is capable of sustaining moderate cyclic deformations beyond the attainment of nominal strength without significant loss of strength.

**Nonductile element.** An element having a mode of failure that results in an abrupt loss of resistance when the element is deformed beyond the deformation corresponding to the development of its nominal strength. Nonductile elements cannot reliably sustain significant deformation beyond that attained at their nominal strength.

**EQUIPMENT SUPPORT.** Those structural members or assemblies of members or manufactured elements, including braces, frames, lugs, snuggers, hangers or saddles, that transmit gravity load and operating load between the equipment and the structure.

**ESSENTIAL FACILITIES.** Buildings and other structures that are intended to remain operational in the event of extreme environmental loading from flood, wind, snow or earthquakes.

**FACTORED LOAD.** The product of a nominal load and a load factor.

**FLEXIBLE EQUIPMENT CONNECTIONS.** Those connections between equipment components that permit rota-

tional and/or translational movement without degradation of performance.

#### FRAME.

**Braced frame.** An essentially vertical truss, or its equivalent, of the concentric or eccentric type that is provided in a building frame system or dual system to resist lateral forces.

**Concentrically braced frame (CBF).** A braced frame in which the members are subjected primarily to axial forces.

**Eccentrically braced frame (EBF).** A diagonally braced frame in which at least one end of each brace frames into a beam a short distance from a beam-column or from another diagonal brace.

**Ordinary concentrically braced frame (OCBF).** A steel concentrically braced frame in which members and connections are designed in accordance with the provisions of AISC Seismic without modification.

**Special concentrically braced frame (SCBF).** A steel or composite steel and concrete concentrically braced frame in which members and connections are designed for ductile behavior.

**Moment frame.** A frame in which members and joints resist lateral forces by flexure as well as along the axis of the members. Moment frames are categorized as “intermediate moment frames” (IMF), “ordinary moment frames” (OMF), and “special moment frames” (SMF).

**GUARD.** See Section 1002.1.

**IMPACT LOAD.** The load resulting from moving machinery, elevators, craneways, vehicles and other similar forces and kinetic loads, pressure and possible surcharge from fixed or moving loads.

**JOINT.** A portion of a column bounded by the highest and lowest surfaces of the other members framing into it.

**LIMIT STATE.** A condition beyond which a structure or member becomes unfit for service and is judged to be no longer useful for its intended function (serviceability limit state) or to be unsafe (strength limit state).

**LIVE LOADS.** Those loads produced by the use and occupancy of the building or other structure and do not include construction or environmental loads such as wind load, snow load, rain load, earthquake load, flood load or dead load.

**LIVE LOADS (ROOF).** Those loads produced (1) during maintenance by workers, equipment and materials; and (2) during the life of the structure by movable objects such as planters and by people.

**LOAD AND RESISTANCE FACTOR DESIGN (LRFD).** A method of proportioning structural members and their connections using load and resistance factors such that no applicable limit state is reached when the structure is subjected to appropriate load combinations. The term “LRFD” is used in the design of steel and wood structures.

**LOAD FACTOR.** A factor that accounts for deviations of the actual load from the nominal load, for uncertainties in the analysis that transforms the load into a load effect, and for the prob-

ability that more than one extreme load will occur simultaneously.

**LOADS.** Forces or other actions that result from the weight of building materials, occupants and their possessions, environmental effects, differential movement and restrained dimensional changes. Permanent loads are those loads in which variations over time are rare or of small magnitude, such as dead loads. All other loads are variable loads (see also “Nominal loads”).

**LOAD EFFECTS.** Forces and deformations produced in structural members by the applied loads.

**NOMINAL LOADS.** The magnitudes of the loads specified in this chapter (dead, live, soil, wind, snow, rain, flood and earthquake).

#### NOTATIONS.

$D$  = Dead load.

$E$  = Combined effect of horizontal and vertical earthquake-induced forces as defined in Sections 1616.4.1 and 1617.1.

$E_m$  = Maximum seismic load effect of horizontal and vertical seismic forces as set forth in Sections 1616.4.1 and 1617.1.

$F$  = Load due to fluids.

$F_a$  = Flood load.

$H$  = Load due to lateral pressure of soil and water in soil.

$L$  = Live load, except roof live load, including any permitted live load reduction.

$L_r$  = Roof live load including any permitted live load reduction.

$P$  = Ponding load.

$R$  = Rain load.

$S$  = Snow load.

$T$  = Self-straining force arising from contraction or expansion resulting from temperature change, shrinkage, moisture change, creep in component materials, movement due to differential settlement or combinations thereof.

$W$  = Load due to wind pressure.

**OTHER STRUCTURES.** Structures, other than buildings, for which loads are specified in this chapter.

**P-DELTA EFFECT.** The second order effect on shears, axial forces and moments of frame members induced by axial loads on a laterally displaced building frame.

**PANEL (PART OF A STRUCTURE).** The section of a floor, wall or roof comprised between the supporting frame of two adjacent rows of columns and girders or column bands of floor or roof construction.

**RESISTANCE FACTOR.** A factor that accounts for deviations of the actual strength from the nominal strength and the manner and consequences of failure (also called “strength reduction factor”).

**SHALLOW ANCHORS.** Shallow anchors are those with embedment length-to-diameter ratios of less than eight.

**SHEAR PANEL.** A floor, roof or wall component sheathed to act as a shear wall or diaphragm.

**SHEAR WALL.** A wall designed to resist lateral forces parallel to the plane of the wall.

**SPACE FRAME.** A structure composed of interconnected members, other than bearing walls, that is capable of supporting vertical loads and that also may provide resistance to seismic lateral forces.

**SPECIAL TRANSVERSE REINFORCEMENT.** Reinforcement composed of spirals, closed stirrups or hoops and supplementary cross ties provided to restrain the concrete and qualify the portion of the component, where used, as a confined region.

**STRENGTH, NOMINAL.** The capacity of a structure or member to resist the effects of loads, as determined by computations using specified material strengths and dimensions and equations derived from accepted principles of structural mechanics or by field tests or laboratory tests of scaled models, allowing for modeling effects and differences between laboratory and field conditions.

**STRENGTH, REQUIRED.** Strength of a member, cross section or connection required to resist factored loads or related internal moments and forces in such combinations as stipulated by these provisions.

**STRENGTH DESIGN.** A method of proportioning structural members such that the computed forces produced in the members by factored loads do not exceed the member design strength [also called “load and resistance factor design” (LRFD)]. The term “strength design” is used in the design of concrete and masonry structural elements.

**WALL, LOAD BEARING.** Any wall meeting either of the following classifications:

1. Any metal or wood stud wall that supports more than 100 pounds per linear foot (plf) (1459 N/m) of vertical load in addition to its own weight.
2. Any masonry or concrete wall that supports more than 200 plf (2919 N/m) of vertical load in addition to its own weight.

**WALL, NONLOAD BEARING.** Any wall that is not a load-bearing wall.

## SECTION 1603 CONSTRUCTION DOCUMENTS

**1603.1 General.** Construction documents shall show the size, section and relative locations of structural members with floor levels, column centers and offsets fully dimensioned. The design loads and other information pertinent to the structural design required by Sections 1603.1.1 through 1603.1.8 shall be clearly indicated on the construction documents for parts of the building or structure.

**Exception:** Construction documents for buildings constructed in accordance with the conventional light-frame

construction provisions of Section 2308 shall indicate the following structural design information:

1. Floor and roof live loads.
2. Ground snow load,  $P_g$ .
3. Basic wind speed (3-second gust), miles per hour (mph) (km/hr) and wind exposure.
4. Seismic design category and site class.

**1603.1.1 Floor live load.** The uniformly distributed, concentrated and impact floor live load used in the design shall be indicated for floor areas. Live load reduction of the uniformly distributed floor live loads, if used in the design, shall be indicated.

**1603.1.2 Roof live load.** The roof live load used in the design shall be indicated for roof areas (Section 1607.11).

**1603.1.3 Roof snow load.** The ground snow load,  $P_g$ , shall be indicated. In areas where the ground snow load,  $P_g$ , exceeds 10 pounds per square foot (psf) (0.479 kN/m<sup>2</sup>), the following additional information shall also be provided, regardless of whether snow loads govern the design of the roof:

1. Flat-roof snow load,  $P_f$ .
2. Snow exposure factor,  $C_e$ .
3. Snow load importance factor,  $I_s$ .
4. Thermal factor,  $C_r$ .

**1603.1.4 Wind design data.** The following information related to wind loads shall be shown, regardless of whether wind loads govern the design of the lateral-force-resisting system of the building:

1. Basic wind speed (3-second gust), miles per hour (km/hr).
2. Wind importance factor,  $I_w$ , and building category.
3. Wind exposure, if more than one wind exposure is utilized, the wind exposure and applicable wind direction shall be indicated.
4. The applicable internal pressure coefficient.
5. Components and cladding. The design wind pressures in terms of psf (kN/m<sup>2</sup>) to be used for the design of exterior component and cladding materials not specifically designed by the registered design professional.

**1603.1.5 Earthquake design data.** The following information related to seismic loads shall be shown, regardless of whether seismic loads govern the design of the lateral-force-resisting system of the building:

1. Seismic importance factor,  $I_E$ , and seismic use group.
2. Mapped spectral response accelerations  $S_S$  and  $S_I$ .
3. Site class.
4. Spectral response coefficients  $S_{DS}$  and  $S_{DI}$ .
5. Seismic design category.
6. Basic seismic-force-resisting system(s).

7. Design base shear.
8. Seismic response coefficient(s),  $C_s$ .
9. Response modification factor(s),  $R$ .
10. Analysis procedure used.

**1603.1.6 Flood load.** For buildings located in flood hazard areas as established in Section 1612.3, the following information, referenced to the datum on the community's Flood Insurance Rate Map (FIRM), shall be shown, regardless of whether flood loads govern the design of the building:

1. In flood hazard areas not subject to high-velocity wave action, the elevation of proposed lowest floor, including basement.
2. In flood hazard areas not subject to high-velocity wave action, the elevation to which any nonresidential building will be dry floodproofed.
3. In flood hazard areas subject to high-velocity wave action, the proposed elevation of the bottom of the lowest horizontal structural member of the lowest floor, including basement.

**1603.1.7 Special loads.** Special loads that are applicable to the design of the building, structure or portions thereof shall be indicated along with the specified section of this code that addresses the special loading condition.

**1603.1.8 Systems and components requiring special inspections for seismic resistance.** Construction documents or specifications shall be prepared for those systems and components requiring special inspection for seismic resistance as specified in Section 1707.1 by the registered design professional responsible for their design and shall be submitted for approval in accordance with Section 106.1. Reference to seismic standards in lieu of detailed drawings is acceptable.

**1603.2 Restrictions on loading.** It shall be unlawful to place, or cause or permit to be placed, on any floor or roof of a building, structure or portion thereof, a load greater than is permitted by these requirements.

**1603.3 Live loads posted.** Where the live loads for which each floor or portion thereof of a commercial or industrial building is or has been designed to exceed 50 psf (2.40 kN/m<sup>2</sup>), such design live loads shall be conspicuously posted by the owner in that part of each story in which they apply, using durable signs. It shall be unlawful to remove or deface such notices.

**1603.4 Occupancy permits for changed loads.** Construction documents for other than residential buildings filed with the building official with applications for permits shall show on each drawing the live loads per square foot (m<sup>2</sup>) of area covered for which the building is designed. Occupancy permits for buildings hereafter erected shall not be issued until the floor load signs, required by Section 1603.3, have been installed.

## SECTION 1604 GENERAL DESIGN REQUIREMENTS

**1604.1 General.** Building, structures and parts thereof shall be designed and constructed in accordance with strength design,



load and resistance factor design, allowable stress design, empirical design or conventional construction methods, as permitted by the applicable material chapters.

**1604.2 Strength.** Buildings and other structures, and parts thereof, shall be designed and constructed to support safely the factored loads in load combinations defined in this code without exceeding the appropriate strength limit states for the materials of construction. Alternatively, buildings and other structures, and parts thereof, shall be designed and constructed to support safely the nominal loads in load combinations defined in this code without exceeding the appropriate specified allowable stresses for the materials of construction.

Loads and forces for occupancies or uses not covered in this chapter shall be subject to the approval of the building official.

**1604.3 Serviceability.** Structural systems and members thereof shall be designed to have adequate stiffness to limit deflections and lateral drift. See Section 1617.3 for drift limits applicable to earthquake loading.

**1604.3.1 Deflections.** The deflections of structural members shall not exceed the more restrictive of the limitations of Sections 1604.3.2 through 1604.3.5 or that permitted by Table 1604.3.

**1604.3.2 Reinforced concrete.** The deflection of reinforced concrete structural members shall not exceed that permitted by ACI 318.

**1604.3.3 Steel.** The deflection of steel structural members shall not exceed that permitted by AISC LRFD, AISC HSS, AISC 335, AISI -NASPEC, AISI-General, AISI-Truss, ASCE 3, ASCE 8-SSD-LRFD/ASD, and the standard specifications of SJI Standard Specifications, Load Tables and Weight Tables for Steel Joists and Joist Girders as applicable.

**1604.3.4 Masonry.** The deflection of masonry structural members shall not exceed that permitted by ACI 530/ASCE 5/TMS 402.

**1604.3.5 Aluminum.** The deflection of aluminum structural members shall not exceed that permitted by AA-ADM1.

**1604.3.6 Limits.** Deflection of structural members over span,  $l$ , shall not exceed that permitted by Table 1604.3.

**1604.4 Analysis.** Load effects on structural members and their connections shall be determined by methods of structural analysis that take into account equilibrium, general stability, geometric compatibility and both short- and long-term material properties.

Members that tend to accumulate residual deformations under repeated service loads shall have included in their analysis the added eccentricities expected to occur during their service life.

Any system or method of construction to be used shall be based on a rational analysis in accordance with well-established principles of mechanics. Such analysis shall result in a system that provides a complete load path capable of transferring loads from their point of origin to the load-resisting elements.

The total lateral force shall be distributed to the various vertical elements of the lateral-force-resisting system in proportion to their rigidities considering the rigidity of the horizontal bracing system or diaphragm. Rigid elements that are assumed not to be a part of the lateral-force-resisting system shall be permitted to be incorporated into buildings provided that their effect on the action of the system is considered and provided for in design. Provisions shall be made for the increased forces induced on resisting elements of the structural system resulting from torsion due to eccentricity between the center of application of the lateral forces and the center of rigidity of the lateral-force-resisting system.

Every structure shall be designed to resist the overturning effects caused by the lateral forces specified in this chapter. See Section 1609 for wind, Section 1610 for lateral soil loads and Sections 1613 through 1623 for earthquake.

**TABLE 1604.3**  
**DEFLECTION LIMITS<sup>a, b, c, h, i</sup>**

CONSTRUCTION	$L$	$S$ or $W^1$	$D + L^{d,g}$
Roof members: <sup>c</sup>			
Supporting plaster ceiling	//360	//360	//240
Supporting nonplaster ceiling	//240	//240	//180
Not supporting ceiling	//180	//180	//120
Floor members	//360	—	//240
Exterior walls and interior partitions:			
With brittle finishes	—	//240	—
With flexible finishes	—	//120	—
Farm buildings	—	—	//180
Greenhouses	—	—	//120

For SI: 1 foot = 304.8 mm.

- a. For structural roofing and siding made of formed metal sheets, the total load deflection shall not exceed //60. For secondary roof structural members supporting formed metal roofing, the live load deflection shall not exceed //150. For secondary wall members supporting formed metal siding, the design wind load deflection shall not exceed //90. For roofs, this exception only applies when the metal sheets have no roof covering.
- b. Interior partitions not exceeding 6 feet in height and flexible, folding and portable partitions are not governed by the provisions of this section. The deflection criterion for interior partitions is based on the horizontal load defined in Section 1607.13.
- c. See Section 2403 for glass supports.
- d. For wood structural members having a moisture content of less than 16 percent at time of installation and used under dry conditions, the deflection resulting from  $L + 0.5D$  is permitted to be substituted for the deflection resulting from  $L + D$ .
- e. The above deflections do not ensure against ponding. Roofs that do not have sufficient slope or camber to assure adequate drainage shall be investigated for ponding. See Section 1611 for rain and ponding requirements and Section 1503.4 for roof drainage requirements.
- f. The wind load is permitted to be taken as 0.7 times the “component and cladding” loads for the purpose of determining deflection limits herein.
- g. For steel structural members, the dead load shall be taken as zero.
- h. For aluminum structural members or aluminum panels used in roofs or walls of sunroom additions or patio covers, not supporting edge of glass or aluminum sandwich panels, the total load deflection shall not exceed //60. For aluminum sandwich panels used in roofs or walls of sunroom additions or patio covers, the total load deflection shall not exceed //120.
- i. For cantilever members,  $l$  shall be taken as twice the length of the cantilever.

**1604.5 Importance factors.** The value for snow load, wind load and seismic load importance factors shall be determined in accordance with Table 1604.5.

**TABLE 1604.5  
CLASSIFICATION OF BUILDINGS AND OTHER STRUCTURES FOR IMPORTANCE FACTORS**

CATEGORY <sup>a</sup>	NATURE OF OCCUPANCY	SEISMIC FACTOR $I_E$	SNOW FACTOR $I_S$	WIND FACTOR $I_W$
I	Buildings and other structures that represent a low hazard to human life in the event of failure including, but not limited to: <ul style="list-style-type: none"> <li>• Agricultural facilities</li> <li>• Certain temporary facilities</li> <li>• Minor storage facilities</li> </ul>	1.00	0.8	0.87 <sup>b</sup>
II	Buildings and other structures except those listed in Categories I, III and IV	1.00	1.0	1.00
III	Buildings and other structures that represent a substantial hazard to human life in the event of failure including, but not limited to: <ul style="list-style-type: none"> <li>• Buildings and other structures where more than 300 people congregate in one area</li> <li>• Buildings and other structures with elementary school, secondary school or day care facilities with an occupant load greater than 250</li> <li>• Buildings and other structures with an occupant load greater than 500 for colleges or adult education facilities</li> <li>• Health care facilities with an occupant load of 50 or more resident patients but not having surgery or emergency treatment facilities</li> <li>• Jails and detention facilities</li> <li>• Any other occupancy with an occupant load greater than 5,000</li> <li>• Power-generating stations, water treatment for potable water, waste water treatment facilities and other public utility facilities not included in Category IV</li> <li>• Buildings and other structures not included in Category IV containing sufficient quantities of toxic or explosive substances to be dangerous to the public if released</li> </ul>	1.25	1.1	1.15
IV	Buildings and other structures designated as essential facilities including, but not limited to: <ul style="list-style-type: none"> <li>• Hospitals and other health care facilities having surgery or emergency treatment facilities</li> <li>• Fire, rescue and police stations and emergency vehicle garages</li> <li>• Designated earthquake, hurricane or other emergency shelters</li> <li>• Designated emergency preparedness, communication, and operation centers and other facilities required for emergency response</li> <li>• Power-generating stations and other public utility facilities required as emergency backup facilities for Category IV structures</li> <li>• Structures containing highly toxic materials as defined by Section 307 where the quantity of the material exceeds the maximum allowable quantities of Table 307.7(2)</li> <li>• Aviation control towers, air traffic control centers and emergency aircraft hangars</li> <li>• Buildings and other structures having critical national defense functions</li> <li>• Water treatment facilities required to maintain water pressure for fire suppression</li> </ul>	1.50	1.2	1.15

a. For the purpose of Section 1616.2, Categories I and II are considered Seismic Use Group I, Category III is considered Seismic Use Group II and Category IV is equivalent to Seismic Use Group III.

b. In hurricane-prone regions with  $V > 100$  miles per hour,  $I_w$  shall be 0.77.

**1604.6 In-situ load tests.** The building official is authorized to require an engineering analysis or a load test, or both, of any construction whenever there is reason to question the safety of the construction for the intended occupancy. Engineering analysis and load tests shall be conducted in accordance with Section 1713.

**1604.7 Preconstruction load tests.** Materials and methods of construction that are not capable of being designed by approved engineering analysis or that do not comply with the applicable material design standards listed in Chapter 35, or alternative test procedures in accordance with Section 1711, shall be load tested in accordance with Section 1714.

**1604.8 Anchorage.**

**1604.8.1 General.** Anchorage of the roof to walls and columns, and of walls and columns to foundations, shall be provided to resist the uplift and sliding forces that result from the application of the prescribed loads.

**1604.8.2 Concrete and masonry walls.** Concrete and masonry walls shall be anchored to floors, roofs and other structural elements that provide lateral support for the wall. Such anchorage shall provide a positive direct connection capable of resisting the horizontal forces specified in this chapter but not less than a minimum strength design horizontal force of 280 plf (4.10 kN/m) of wall, substituted for “E” in the load combinations of Section 1605.2 or 1605.3. Walls shall be designed to resist bending between anchors where the anchor spacing exceeds 4 feet (1219 mm). Required anchors in masonry walls of hollow units or cavity walls shall be embedded in a reinforced grouted structural element of the wall. See Sections 1609.6.2.2 and 1620 for wind and earthquake design requirements.

**1604.8.3 Decks.** Where supported by attachment to an exterior wall, decks shall be positively anchored to the primary structure and designed for both vertical and lateral loads as applicable. Such attachment shall not be accomplished by the use of toenails or nails subject to withdrawal. Where positive connection to the primary building structure cannot be verified during inspection, decks shall be self-supporting. For decks with cantilevered framing members, connections to exterior walls or other framing members shall be designed and constructed to resist uplift resulting from the full live load specified in Table 1607.1 acting on the cantilevered portion of the deck.

**SECTION 1605  
LOAD COMBINATIONS**

**1605.1 General.** Buildings and other structures and portions thereof shall be designed to resist the load combinations specified in Section 1605.2 or 1605.3 and Chapters 18 through 23, and the special seismic load combinations of Section 1605.4 where required by Section 1620.2.6, 1620.2.9 or 1620.4.4 or Section 9.5.2.6.2.11 or 9.5.2.6.3.1 of ASCE 7. Applicable loads shall be considered, including both earthquake and wind, in accordance with the specified load combinations. Each load combination shall also be investigated with one or more of the variable loads set to zero.

**1605.2 Load combinations using strength design or load and resistance factor design.**

**1605.2.1 Basic load combinations.** Where strength design or load and resistance factor design is used, structures and

portions thereof shall resist the most critical effects from the following combinations of factored loads:

$1.4D$  (Equation 16-1)

$1.2D + 1.6L + 0.5(L_r \text{ or } S \text{ or } R)$  (Equation 16-2)

$1.2D + 1.6(L_r \text{ or } S \text{ or } R) + (f_1L \text{ or } 0.8W)$  (Equation 16-3)

$1.2D + 1.6W + f_1L + 0.5(L_r \text{ or } S \text{ or } R)$  (Equation 16-4)

$1.2D + 1.0E + f_1L + f_2S$  (Equation 16-5)

$0.9D + (1.0E \text{ or } 1.6W)$  (Equation 16-6)

where:

$f_1 = 1.0$  for floors in places of public assembly, for live loads in excess of 100 pounds per square foot (4.79 kN/m<sup>2</sup>), and for parking garage live load.

$f_1 = 0.5$  for other live loads.

$f_2 = 0.7$  for roof configurations (such as saw tooth) that do not shed snow off the structure.

$f_2 = 0.2$  for other roof configurations.

**Exception:** Where other factored load combinations are specifically required by the provisions of this code, such combinations shall take precedence.

**1605.2.2 Other loads.** Where  $F$ ,  $H$ ,  $P$  or  $T$  is to be considered in design, each applicable load shall be added to the above combinations in accordance with Section 2.3.2 of ASCE 7. Where  $F_a$  is to be considered in design, the load combinations of Section 2.3.3 of ASCE 7 shall be used.

**1605.3 Load combinations using allowable stress design.**

**1605.3.1 Basic load combinations.** Where allowable stress design (working stress design), as permitted by this code, is used, structures and portions thereof shall resist the most critical effects resulting from the following combinations of loads:

$D$  (Equation 16-7)

$D + L$  (Equation 16-8)

$D + L + (L_r \text{ or } S \text{ or } R)$  (Equation 16-9)

$D + (W \text{ or } 0.7E) + L + (L_r \text{ or } S \text{ or } R)$  (Equation 16-10)

$0.6D + W$  (Equation 16-11)

$0.6D + 0.7E$  (Equation 16-12)

**Exceptions:**

1. Crane hook loads need not be combined with roof live load or with more than three-fourths of the snow load or one-half of the wind load.
2. Flat roof snow loads of 30 psf (1.44 kN/m<sup>2</sup>) or less need not be combined with seismic loads. Where flat roof snow loads exceed 30 psf (1.44 kN/m<sup>2</sup>), 20 percent shall be combined with seismic loads.

**1605.3.1.1 Load reduction.** It is permitted to multiply the combined effect of two or more variable loads by 0.75 and add to the effect of dead load. The combined load used in design shall not be less than the sum of the

effects of dead load and any one of the variable loads. The 0.7 factor on  $E$  does not apply for this provision.

Increases in allowable stresses specified in the appropriate materials section of this code or referenced standard shall not be used with the load combinations of Section 1605.3.1 except that a duration of load increase shall be permitted in accordance with Chapter 23.

**1605.3.1.2 Other loads.** Where  $F$ ,  $H$ ,  $P$  or  $T$  are to be considered in design, the load combinations of Section 2.4.1 of ASCE 7 shall be used. Where  $F_a$  is to be considered in design, the load combinations of Section 2.4.2 of ASCE 7 shall be used.

**1605.3.2 Alternative basic load combinations.** In lieu of the basic load combinations specified in Section 1605.3.1, structures and portions thereof shall be permitted to be designed for the most critical effects resulting from the following combinations. When using these alternate basic load combinations that include wind or seismic loads, allowable stresses are permitted to be increased or load combinations reduced, where permitted by the material section of this code or referenced standard. Where wind loads are calculated in accordance with Section 1609.6 or Section 6 of ASCE 7, the coefficient  $\omega$  in the following equations shall be taken as 1.3. For other wind loads  $\omega$  shall be taken as 1.0.

$$D + L + (L_r \text{ or } S \text{ or } R) \quad \text{(Equation 16-13)}$$

$$D + L + (\omega W) \quad \text{(Equation 16-14)}$$

$$D + L + \omega W + S/2 \quad \text{(Equation 16-15)}$$

$$D + L + S + \omega W/2 \quad \text{(Equation 16-16)}$$

$$D + L + S + E/1.4 \quad \text{(Equation 16-17)}$$

$$0.9D + E/1.4 \quad \text{(Equation 16-18)}$$

**Exceptions:**

1. Crane hook loads need not be combined with roof live load or with more than three-fourths of the snow load or one-half of the wind load.
2. Flat roof snow loads of 30 pounds per square foot (1.44 kN/m<sup>2</sup>) or less need not be combined with seismic loads. Where flat roof snow loads exceed 30 psf (1.44 kN/m<sup>2</sup>), 20 percent shall be combined with seismic loads.

**1605.3.2.1 Other loads.** Where  $F$ ,  $H$ ,  $P$  or  $T$  are to be considered in design, 1.0 times each applicable load shall be added to the combinations specified in Section 1605.3.2.

**1605.4 Special seismic load combinations.** For both allowable stress design and strength design methods, where specifically required by Sections 1613 through 1622 or by Chapters 18 through 23, elements and components shall be designed to resist the forces calculated using Equation 16-19 when the effects of the seismic ground motion are additive to gravity forces and those calculated using Equation 16-20 when the effects of the seismic ground motion counteract gravity forces.

$$1.2D + f_i L + E_m \quad \text{(Equation 16-19)}$$

$$0.9D + E_m \quad \text{(Equation 16-20)}$$

where:

$E_m$  = The maximum effect of horizontal and vertical forces as set forth in Section 1617.1.

$f_i$  = 1.0 for floors in places of public assembly, for live loads in excess of 100 psf (4.79 kN/m<sup>2</sup>) and for parking garage live load.

$f_i$  = 0.5 for other live loads.

**1605.5 Heliports and helistops.** Heliport and helistop landing or touchdown areas shall be designed for the following loads, combined in accordance with Section 1605:

1. Dead load,  $D$ , plus the gross weight of the helicopter,  $D_h$ , plus snow load,  $S$ .
2. Dead load,  $D$ , plus two single concentrated impact loads,  $L$ , approximately 8 feet (2438 mm) apart applied anywhere on the touchdown pad (representing each of the helicopter's two main landing gear, whether skid type or wheeled type), having a magnitude of 0.75 times the gross weight of the helicopter. Both loads acting together total 1.5 times the gross weight of the helicopter.
3. Dead load,  $D$ , plus a uniform live load,  $L$ , of 100 psf (4.79 kN/m<sup>2</sup>).

**SECTION 1606  
DEAD LOADS**

**1606.1 Weights of materials and construction.** In determining dead loads for purposes of design, the actual weights of materials and construction shall be used. In the absence of definite information, values used shall be subject to the approval of the building official.

**1606.2 Weights of fixed service equipment.** In determining dead loads for purposes of design, the weight of fixed service equipment, such as plumbing stacks and risers, electrical feeders, heating, ventilating and air-conditioning systems (HVAC) and fire sprinkler systems, shall be included.

**SECTION 1607  
LIVE LOADS**

**1607.1 General.** Live loads are those loads defined in Section 1602.1.

**1607.2 Loads not specified.** For occupancies or uses not designated in Table 1607.1, the live load shall be determined in accordance with a method approved by the building official.

**1607.3 Uniform live loads.** The live loads used in the design of buildings and other structures shall be the maximum loads expected by the intended use or occupancy but shall in no case be less than the minimum uniformly distributed unit loads required by Table 1607.1.

**1607.4 Concentrated loads.** Floors and other similar surfaces shall be designed to support the uniformly distributed live loads prescribed in Section 1607.3 or the concentrated load, in pounds (kilonewtons), given in Table 1607.1, whichever produces the greater load effects. Unless otherwise specified, the indicated concentration shall be assumed to be uniformly distributed over an area 2.5 feet by 2.5 feet [6.25 ft<sup>2</sup> (0.58 m<sup>2</sup>)] and shall be located so as to produce the maximum load effects in the structural members.



**TABLE 1607.1  
MINIMUM UNIFORMLY DISTRIBUTED LIVE LOADS AND MINIMUM CONCENTRATED LIVE LOADS<sup>9</sup>**

OCCUPANCY OR USE	UNIFORM (psf)	CONCENTRATED (lbs.)
1. Apartments (see residential)	—	—
2. Access floor systems		
Office use	50	2,000
Computer use	100	2,000
3. Armories and drill rooms	150	—
4. Assembly areas and theaters		
Fixed seats (fastened to floor)	60	
Lobbies	100	
Movable seats	100	—
Stages and platforms	125	
Follow spot, projections and control rooms	50	
Catwalks	40	
5. Balconies (exterior)	100	
On one- and two-family residences only, and not exceeding 100 ft. <sup>2</sup>	60	—
6. Decks	Same as occupancy served <sup>h</sup>	—
7. Bowling alleys	75	—
8. Cornices	60	—
9. Corridors, except as otherwise indicated	100	—
10. Dance halls and ballrooms	100	—
11. Dining rooms and restaurants	100	—
12. Dwellings (see residential)	—	—
13. Elevator machine room grating (on area of 4 in. <sup>2</sup> )	—	300
14. Finish light floor plate construction (on area of 1 in. <sup>2</sup> )	—	200
15. Fire escapes	100	
On single-family dwellings only	40	—
16. Garages (passenger vehicles only)	40	Note a
Trucks and buses	See Section 1607.6	
17. Grandstands (see stadium and arena bleachers)	—	—
18. Gymnasiums, main floors and balconies	100	—
19. Handrails, guards and grab bars	See Section 1607.7	
20. Hospitals		
Operating rooms, laboratories	60	1,000
Private rooms	40	1,000
Wards	40	1,000
Corridors above first floor	80	1,000
21. Hotels (see residential)	—	—
22. Libraries		
Reading rooms	60	1,000
Stack rooms	150 <sup>b</sup>	1,000
Corridors above first floor	80	1,000
23. Manufacturing		
Light	125	2,000
Heavy	250	3,000
24. Marquees	75	—

OCCUPANCY OR USE	UNIFORM (psf)	CONCENTRATED (lbs.)
25. Office buildings		
File and computer rooms shall be designed for heavier loads based on anticipated occupancy		
Lobbies and first-floor corridors	100	2,000
Offices	50	2,000
Corridors above first floor	80	2,000
26. Penal institutions		
Cell blocks	40	—
Corridors	100	—
27. Residential		
One- and two-family dwellings		
Uninhabitable attics without storage	10	
Uninhabitable attics with storage	20	
Habitable attics and sleeping areas	30	
All other areas except balconies and decks	40	—
Hotels and multifamily dwellings		
Private rooms and corridors serving them	40	
Public rooms and corridors serving them	100	
28. Reviewing stands, grandstands and bleachers	Note c	—
29. Roofs	See Section 1607.11	
30. Schools		
Classrooms	40	1,000
Corridors above first floor	80	1,000
First-floor corridors	100	1,000
31. Scuttles, skylight ribs and accessible ceilings	—	200
32. Sidewalks, vehicular driveways and yards, subject to trucking	250 <sup>d</sup>	8,000 <sup>e</sup>
33. Skating rinks	100	—
34. Stadiums and arenas		
Bleachers	100 <sup>c</sup>	—
Fixed seats (fastened to floor)	60 <sup>c</sup>	
35. Stairs and exits		
One- and two-family dwellings	100	Note f
All other	40	
All other	100	
36. Storage warehouses (shall be designed for heavier loads if required for anticipated storage)		
Light	125	—
Heavy	250	
37. Stores		
Retail		
First floor	100	1,000
Upper floors	75	1,000
Wholesale, all floors	125	1,000
38. Vehicle barriers	See Section 1607.7	
39. Walkways and elevated platforms (other than exitways)	60	—
40. Yards and terraces, pedestrians	100	—

(continued)

**Notes to Table 1607.1**

For SI: 1 inch = 25.4 mm, 1 square inch = 645.16 mm<sup>2</sup>, 1 pound per square foot = 0.0479 kN/m<sup>2</sup>, 1 pound = 0.004448 kN.

1 pound per cubic foot = 16 kg/m<sup>3</sup>

- a. Floors in garages or portions of buildings used for the storage of motor vehicles shall be designed for the uniformly distributed live loads of Table 1607.1 or the following concentrated loads: (1) for garages restricted to vehicles accommodating not more than nine passengers, 3,000 pounds acting on an area of 4.5 inches by 4.5 inches; (2) for mechanical parking structures without slab or deck which are used for storing passenger vehicles only, 2,250 pounds per wheel.
- b. The loading applies to stack room floors that support nonmobile, double-faced library bookstacks, subject to the following limitations:
  - 1. The nominal bookstack unit height shall not exceed 90 inches;
  - 2. The nominal shelf depth shall not exceed 12 inches for each face; and
  - 3. Parallel rows of double-faced bookstacks shall be separated by aisles not less than 36 inches wide.
- c. Design in accordance with the ICC *Standard on Bleachers, Folding and Telescopic Seating and Grandstands*.
- d. Other uniform loads in accordance with an approved method which contains provisions for truck loadings shall also be considered where appropriate.
- e. The concentrated wheel load shall be applied on an area of 20 square inches.
- f. Minimum concentrated load on stair treads (on area of 4 square inches) is 300 pounds.
- g. Where snow loads occur that are in excess of the design conditions, the structure shall be designed to support the loads due to the increased loads caused by drift buildup or a greater snow design determined by the building official (see Section 1608). For special-purpose roofs, see Section 1607.11.2.2.
- h. See Section 1604.8.3 for decks attached to exterior walls.

**1607.5 Partition loads.** In office buildings and in other buildings where partition locations are subject to change, provision for partition weight shall be made, whether or not partitions are shown on the construction documents, unless the specified live load exceeds 80 psf (3.83 kN/m<sup>2</sup>). Such partition load shall not be less than a uniformly distributed live load of 20 psf (0.96kN/m<sup>2</sup>).

**1607.6 Truck and bus garages.** Minimum live loads for garages having trucks or buses shall be as specified in Table 1607.6, but shall not be less than 50 psf (2.40 kN/m<sup>2</sup>), unless other loads are specifically justified and approved by the building official. Actual loads shall be used where they are greater than the loads specified in the table.

**1607.6.1 Truck and bus garage live load application.** The concentrated load and uniform load shall be uniformly distributed over a 10-foot (3048 mm) width on a line normal to the centerline of the lane placed within a 12-foot-wide (3658 mm) lane. The loads shall be placed within their individual lanes so as to produce the maximum stress in each structural member. Single spans shall be designed for the uniform load in Table 1607.6 and one simultaneous concentrated load positioned to produce the maximum effect. Multiple spans shall be designed for the uniform load in Table 1607.6 on the spans and two simultaneous concentrated loads in two spans positioned to produce the maximum negative moment effect. Multiple span design loads, for other effects, shall be the same as for single spans.

**1607.7 Loads on handrails, guards, grab bars and vehicle barriers.** Handrails, guards, grab bars as designed in ICC A117.1 and vehicle barriers shall be designed and constructed to the structural loading conditions set forth in this section.

**TABLE 1607.6  
UNIFORM AND CONCENTRATED LOADS**

LOADING CLASS <sup>a</sup>	UNIFORM LOAD (pounds/linear foot of lane)	CONCENTRATED LOAD (pounds) <sup>b</sup>	
		For moment design	For shear design
H20-44 and HS20-44	640	18,000	26,000
H15-44 and HS15-44	480	13,500	19,500

For SI: 1 pound per linear foot = 0.01459 kN/m, 1 pound = 0.004448 kN, 1 ton = 8.90 kN.

- a. An H loading class designates a two-axle truck with a semitrailer. An HS loading class designates a tractor truck with a semitrailer. The numbers following the letter classification indicate the gross weight in tons of the standard truck and the year the loadings were instituted.
- b. See Section 1607.6.1 for the loading of multiple spans.

**1607.7.1 Handrails and guards.** Handrail assemblies and guards shall be designed to resist a load of 50 plf (0.73 kN/m) applied in any direction at the top and to transfer this load through the supports to the structure.

**Exceptions:**

- 1. For one- and two-family dwellings, only the single, concentrated load required by Section 1607.7.1.1 shall be applied.
- 2. In Group I-3, F, H and S occupancies, for areas that are not accessible to the general public and that have an occupant load no greater than 50, the minimum load shall be 20 pounds per foot (0.29 kN/m).

**1607.7.1.1 Concentrated load.** Handrail assemblies and guards shall be able to resist a single concentrated load of 200 pounds (0.89 kN), applied in any direction at any point along the top, and have attachment devices and supporting structure to transfer this loading to appropriate structural elements of the building. This load need not be assumed to act concurrently with the loads specified in the preceding paragraph.

**1607.7.1.2 Components.** Intermediate rails (all those except the handrail), balusters and panel fillers shall be designed to withstand a horizontally applied normal load of 50 pounds (0.22 kN) on an area equal to 1 square foot (0.093 m<sup>2</sup>), including openings and space between rails. Reactions due to this loading are not required to be superimposed with those of Section 1607.7.1 or 1607.7.1.1.

**1607.7.1.3 Stress increase.** Where handrails and guards are designed in accordance with the provisions for allowable stress design (working stress design) exclusively for the loads specified in Section 1607.7.1, the allowable stress for the members and their attachments are permitted to be increased by one-third.

**1607.7.2 Grab bars, shower seats and dressing room bench seats.** Grab bars, shower seats and dressing room bench seat systems shall be designed to resist a single concentrated load of 250 pounds (1.11 kN) applied in any direction at any point.

**1607.7.3 Vehicle barriers.** Vehicle barrier systems for passenger cars shall be designed to resist a single load of 6,000

pounds (26.70 kN) applied horizontally in any direction to the barrier system and shall have anchorage or attachment capable of transmitting this load to the structure. For design of the system, the load shall be assumed to act at a minimum height of 1 foot, 6 inches (457 mm) above the floor or ramp surface on an area not to exceed 1 square foot (305 mm<sup>2</sup>), and is not required to be assumed to act concurrently with any handrail or guard loadings specified in the preceding paragraphs of Section 1607.7.1. Garages accommodating trucks and buses shall be designed in accordance with an approved method that contains provision for traffic railings.

**1607.8 Impact loads.** The live loads specified in Section 1607.3 include allowance for impact conditions. Provisions shall be made in the structural design for uses and loads that involve unusual vibration and impact forces.

**1607.8.1 Elevators.** Elevator loads shall be increased by 100 percent for impact and the structural supports shall be designed within the limits of deflection prescribed by ASME A17.1.

**1607.8.2 Machinery.** For the purpose of design, the weight of machinery and moving loads shall be increased as follows to allow for impact: (1) elevator machinery, 100 percent; (2) light machinery, shaft- or motor-driven, 20 percent; (3) reciprocating machinery or power-driven units, 50 percent; (4) hangers for floors or balconies, 33 percent. Percentages shall be increased where specified by the manufacturer.

**1607.9 Reduction in live loads.** The minimum uniformly distributed live loads,  $L_o$ , in Table 1607.1 are permitted to be reduced according to the following provisions.

**1607.9.1 General.** Subject to the limitations of Sections 1607.9.1.1 through 1607.9.1.4, members for which a value of  $K_{LL}A_T$  is 400 square feet (37.16 m<sup>2</sup>) or more are permitted to be designed for a reduced live load in accordance with the following equation:

$$L = L_o \left( 0.25 + \frac{15}{\sqrt{K_{LL}A_T}} \right) \quad \text{(Equation 16-21)}$$

$$\text{For SI: } L = L_o \left( 0.25 + \frac{457}{\sqrt{K_{LL}A_T}} \right)$$

where:

$L$  = Reduced design live load per square foot (meter) of area supported by the member.

$L_o$  = Unreduced design live load per square foot (meter) of area supported by the member (see Table 1607.1).

$K_{LL}$  = Live load element factor (see Table 1607.9.1).

$A_T$  = Tributary area, in square feet (square meters).  $L$  shall not be less than  $0.50L_o$  for members supporting one floor and  $L$  shall not be less than  $0.40L_o$  for members supporting two or more floors.

**TABLE 1607.9.1  
LIVE LOAD ELEMENT FACTOR,  $K_{LL}$**

ELEMENT	$K_{LL}$
Interior columns	4
Exterior columns without cantilever slabs	4
Edge columns with cantilever slabs	3
Corner columns with cantilever slabs	2
Edge beams without cantilever slabs	2
Interior beams	2
All other members not identified above including: Edge beams with cantilever slabs Cantilever beams Two-way slabs Members without provisions for continuous shear transfer normal to their span	1

**1607.9.1.1 Heavy live loads.** Live loads that exceed 100 psf (4.79 kN/m<sup>2</sup>) shall not be reduced except the live loads for members supporting two or more floors are permitted to be reduced by a maximum of 20 percent, but the live load shall not be less than  $L$  as calculated in Section 1607.9.1.

**1607.9.1.2 Passenger vehicle garages.** The live loads shall not be reduced in passenger vehicle garages except the live loads for members supporting two or more floors are permitted to be reduced by a maximum of 20 percent, but the live load shall not be less than  $L$  as calculated in Section 1607.9.1.

**1607.9.1.3 Special occupancies.** Live loads of 100 psf (4.79 kN/m<sup>2</sup>) or less shall not be reduced in public assembly occupancies.

**1607.9.1.4 Special structural elements.** Live loads shall not be reduced for one-way slabs except as permitted in Section 1607.9.1.1. Live loads of 100 psf (4.79 kN/m<sup>2</sup>) or less shall not be reduced for roof members except as specified in Section 1607.11.2.

**1607.9.2 Alternate floor live load reduction.** As an alternative to Section 1607.9.1, floor live loads are permitted to be reduced in accordance with the following provisions. Such reductions shall apply to slab systems, beams, girders, columns, piers, walls and foundations.

1. A reduction shall not be permitted in Group A occupancies.
2. A reduction shall not be permitted when the live load exceeds 100 psf (4.79 kN/m<sup>2</sup>) except that the design live load for columns may be reduced by 20 percent.
3. For live loads not exceeding 100 psf (4.79 kN/m<sup>2</sup>), the design live load for any structural member supporting 150 square feet (13.94 m<sup>2</sup>) or more is permitted to be reduced in accordance with the following equation:

$$R = r(A - 150) \quad \text{(Equation 16-22)}$$

$$\text{For SI: } R = r(A - 13.94)$$

Such reduction shall not exceed 40 percent for horizontal members, 60 percent for vertical members, nor  $R$  as determined by the following equation:

$$R = 23.1 (1 + D/L_o) \quad \text{(Equation 16-23)}$$

where:

$A$  = Area of floor or roof supported by the member, square feet ( $m^2$ ).

$D$  = Dead load per square foot ( $m^2$ ) of area supported.

$L_o$  = Unreduced live load per square foot ( $m^2$ ) of area supported.

$R$  = Reduction in percent.

$r$  = Rate of reduction equal to 0.08 percent per square foot ( $0.090293 m^2$ ) for floors.

**1607.10 Distribution of floor loads.** Where uniform floor live loads are involved in the design of structural members arranged so as to create continuity, the minimum applied loads shall be the full dead loads on all spans in combination with the floor live loads on spans selected to produce the greatest effect at each location under consideration. It shall be permitted to reduce floor live loads in accordance with Section 1607.9.

**1607.11 Roof loads.** The structural supports of roofs and marquees shall be designed to resist wind and, where applicable, snow and earthquake loads, in addition to the dead load of construction and the appropriate live loads as prescribed in this section, or as set forth in Table 1607.1. The live loads acting on a sloping surface shall be assumed to act vertically on the horizontal projection of that surface.

**1607.11.1 Distribution of roof loads.** Where uniform roof live loads are involved in the design of structural members arranged so as to create continuity, the minimum applied loads shall be the full dead loads on all spans in combination with the roof live loads on adjacent spans or on alternate spans, whichever produces the greatest effect. See Section 1607.11.2 for minimum roof live loads and Section 1608.5 for partial snow loading.

**1607.11.2 Minimum roof live loads.** Minimum roof loads shall be determined for the specific conditions in accordance with Sections 1607.11.2.1 through 1607.11.2.4.

**1607.11.2.1 Flat, pitched and curved roofs.** Ordinary flat, pitched and curved roofs shall be designed for the live loads specified in the following equation or other controlling combinations of loads in Section 1605, whichever produces the greater load. In structures where special scaffolding is used as a work surface for workers and materials during maintenance and repair operations, a lower roof load than specified in the following equation shall not be used unless approved by the building official. Greenhouses shall be designed for a minimum roof live load of 10 psf ( $0.479 kN/m^2$ ).

$$L_r = 20R_1R_2 \quad \text{(Equation 16-24)}$$

where:  $12 \leq L_r \leq 20$

For SI:  $L_r = 0.96 R_1R_2$

where:  $0.58 \leq L_r \leq 0.96$

$L_r$  = Roof live load per square foot ( $m^2$ ) of horizontal projection in pounds per square foot ( $kN/m^2$ ).

The reduction factors  $R_1$  and  $R_2$  shall be determined as follows:

$$R_1 = 1 \quad \text{for } A_t \leq 200 \text{ square feet (18.58 } m^2) \quad \text{(Equation 16-25)}$$

$$R_1 = 1.2 - 0.001A_t \quad \text{for } 200 \text{ square feet} < A_t < 600 \text{ square feet} \quad \text{(Equation 16-26)}$$

For SI:  $1.2 - 0.011A_t$  for 18.58 square meters  $< A_t < 55.74$  square meters

$$R_1 = 0.6 \quad \text{for } A_t \geq 600 \text{ square feet (55.74 } m^2) \quad \text{(Equation 16-27)}$$

where:

$A_t$  = Tributary area (span length multiplied by effective width) in square feet ( $m^2$ ) supported by any structural member, and

$F$  = for a sloped roof, the number of inches of rise per foot (for SI:  $F = 0.12 \times$  slope, with slope expressed in percentage points), and

$F$  = for an arch or dome, rise-to-span ratio multiplied by 32, and

$$R_2 = 1 \quad \text{for } F \leq 4 \quad \text{(Equation 16-28)}$$

$$R_2 = 1.2 - 0.05 F \quad \text{for } 4 < F < 12 \quad \text{(Equation 16-29)}$$

$$R_2 = 0.6 \quad \text{for } F \geq 12 \quad \text{(Equation 16-30)}$$

**1607.11.2.2 Special-purpose roofs.** Roofs used for promenade purposes shall be designed for a minimum live load of 60 psf ( $2.87 kN/m^2$ ). Roofs used for roof gardens or assembly purposes shall be designed for a minimum live load of 100 psf ( $4.79 kN/m^2$ ). Roofs used for other special purposes shall be designed for appropriate loads, as directed or approved by the building official.

**1607.11.2.3 Landscaped roofs.** Where roofs are to be landscaped, the uniform design live load in the landscaped area shall be 20 psf ( $0.958 kN/m^2$ ). The weight of the landscaping materials shall be considered as dead load and shall be computed on the basis of saturation of the soil.

**1607.11.2.4 Fabric awnings and fabric canopies.** Awnings and canopies shall be designed for a uniform live load of 5 psf ( $0.240 kN/m^2$ ) as well as for snow loads and wind loads as specified in Sections 1608 and 1609.

**1607.12 Crane loads.** The crane live load shall be the rated capacity of the crane. Design loads for the runway beams, including connections and support brackets, of moving bridge cranes and monorail cranes shall include the maximum wheel loads of the crane and the vertical impact, lateral and longitudinal forces induced by the moving crane.



**1607.12.1 Maximum wheel load.** The maximum wheel loads shall be the wheel loads produced by the weight of the bridge, as applicable, plus the sum of the rated capacity and the weight of the trolley with the trolley positioned on its runway at the location where the resulting load effect is maximum.

**1607.12.2 Vertical impact force.** The maximum wheel loads of the crane shall be increased by the percentages shown below to determine the induced vertical impact or vibration force:

- Monorail cranes (powered) . . . . . 25 percent
- Cab-operated or remotely operated bridge cranes (powered) . . . . . 25 percent
- Pendant-operated bridge cranes (powered) . . . . . 10 percent
- Bridge cranes or monorail cranes with hand-gear bridge, trolley and hoist . . . . . 0 percent

**1607.12.3 Lateral force.** The lateral force on crane runway beams with electrically powered trolleys shall be calculated as 20 percent of the sum of the rated capacity of the crane and the weight of the hoist and trolley. The lateral force shall be assumed to act horizontally at the traction surface of a runway beam, in either direction perpendicular to the beam, and shall be distributed according to the lateral stiffness of the runway beam and supporting structure.

**1607.12.4 Longitudinal force.** The longitudinal force on crane runway beams, except for bridge cranes with hand-gear bridges, shall be calculated as 10 percent of the maximum wheel loads of the crane. The longitudinal force shall be assumed to act horizontally at the traction surface of a runway beam, in either direction parallel to the beam.

**1607.13 Interior walls and partitions.** Interior walls and partitions that exceed 6 feet (1829 mm) in height, including their

finish materials, shall have adequate strength to resist the loads to which they are subjected but not less than a horizontal load of 5 psf (0.240 kN/m<sup>2</sup>).

**SECTION 1608  
SNOW LOADS**

**1608.1 General.** Design snow loads shall be determined in accordance with Section 7 of ASCE 7, but the design roof load shall not be less than that determined by Section 1607.

**1608.2 Ground snow loads.** The ground snow loads to be used in determining the design snow loads for roofs are given in Figure 1608.2 for the contiguous United States and Table 1608.2 for Alaska. Site-specific case studies shall be made in areas designated CS in Figure 1608.2. Ground snow loads for sites at elevations above the limits indicated in Figure 1608.2 and for all sites within the CS areas shall be approved. Ground snow load determination for such sites shall be based on an extreme value statistical analysis of data available in the vicinity of the site using a value with a 2-percent annual probability of being exceeded (50-year mean recurrence interval). Snow loads are zero for Hawaii, except in mountainous regions as approved by the building official.

**1608.3 Flat roof snow loads.** The flat roof snow load,  $p_f$ , on a roof with a slope equal to or less than 5 degrees (0.09 rad) (1 inch per foot = 4.76 degrees) shall be calculated in accordance with Section 7.3 of ASCE 7.

**1608.3.1 Exposure factor.** The value for the snow exposure factor,  $C_e$ , used in the calculation of  $p_f$  shall be determined from Table 1608.3.1.

**1608.3.2 Thermal factor.** The value for the thermal factor,  $C_t$ , used in the calculation of  $p_f$  shall be determined from Table 1608.3.2.

**TABLE 1608.2  
GROUND SNOW LOADS,  $p_g$ , FOR ALASKAN LOCATIONS**

LOCATION	POUNDS PER SQUARE FOOT	LOCATION	POUNDS PER SQUARE FOOT	LOCATION	POUNDS PER SQUARE FOOT
Adak	30	Galena	60	Petersburg	150
Anchorage	50	Gulkana	70	St. Paul Islands	40
Angoon	70	Homer	40	Seward	50
Barrow	25	Juneau	60	Shemya	25
Barter Island	35	Kenai	70	Sitka	50
Bethel	40	Kodiak	30	Talkeetna	120
Big Delta	50	Kotzebue	60	Unalakleet	50
Cold Bay	25	McGrath	70	Valdez	160
Cordova	100	Nenana	80	Whittier	300
Fairbanks	60	Nome	70	Wrangell	60
Fort Yukon	60	Palmer	50	Yakutat	150

For SI: 1 pound per square foot = 0.0479 kN/m<sup>2</sup>.

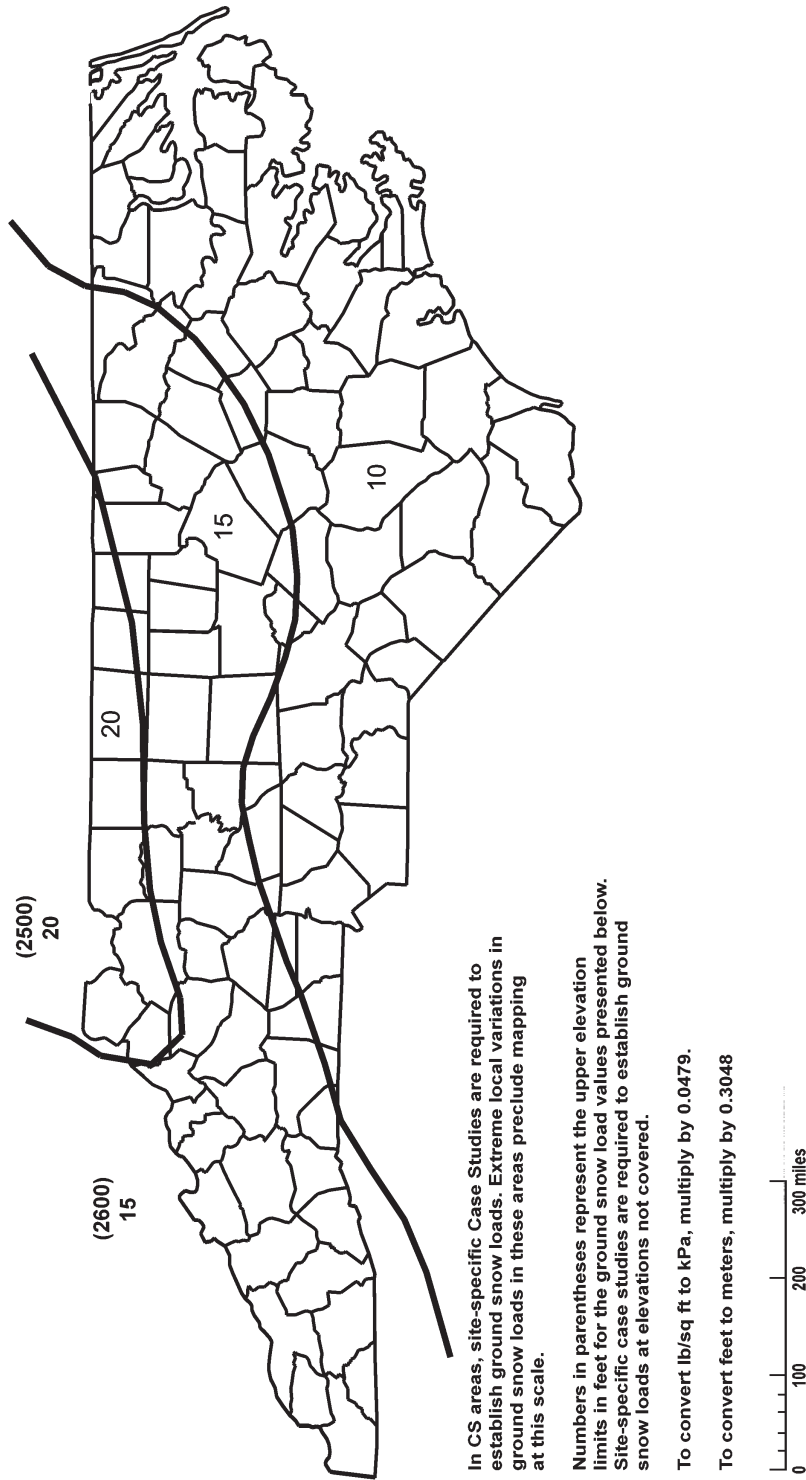

In CS areas, site-specific Case Studies are required to establish ground snow loads. Extreme local variations in ground snow loads in these areas preclude mapping at this scale.

Numbers in parentheses represent the upper elevation limits in feet for the ground snow load values presented below. Site-specific case studies are required to establish ground snow loads at elevations not covered.

To convert lb/sq ft to kPa, multiply by 0.0479.

To convert feet to meters, multiply by 0.3048



FIGURE 1608.2  
GROUND SNOW LOADS,  $p_g$ , FOR THE STATE OF NORTH CAROLINA (psf)

**1608.3.3 Snow load importance factor.** The value for the snow load importance factor,  $I_s$ , used in the calculation of  $p_f$  shall be determined in accordance with Table 1604.5. Greenhouses that are occupied for growing plants on production or research basis, without public access, shall be included in Importance Category I.

**1608.3.4 Rain-on-snow surcharge load.** Roofs with a slope less than  $1/2$  inch per foot (2.38 degrees) shall be designed for a rain-on-snow surcharge load determined in accordance with Section 7.10 of ASCE 7.

**1608.3.5 Ponding instability.** For roofs with a slope less than  $1/4$  inch per foot (1.19 degrees), the design calculations shall include verification of the prevention of ponding instability in accordance with Section 7.11 of ASCE 7.

**1608.4 Sloped roof snow loads.** The snow load,  $p_s$ , on a roof with a slope greater than 5 degrees (0.09 rad) (1 inch per foot = 4.76 degrees) shall be calculated in accordance with Section 7.4 of ASCE 7.

**1608.5 Partial loading.** The effect of not having the balanced snow load over the entire loaded roof area shall be analyzed in accordance with Section 7.5 of ASCE 7.

**1608.6 Unbalanced snow loads.** Unbalanced roof snow loads shall be determined in accordance with Section 7.6 of ASCE 7. Winds from all directions shall be accounted for when establishing unbalanced snow loads.

**1608.7 Drifts on lower roofs.** In areas where the ground snow load,  $p_g$ , as determined by Section 1608.2, is equal to or greater than 5 psf (0.240 kN/m<sup>2</sup>), roofs shall be designed to sustain localized loads from snow drifts in accordance with Section 7.7 of ASCE 7.

**1608.8 Roof projections.** Drift loads due to mechanical equipment, penthouses, parapets and other projections above the roof shall be determined in accordance with Section 7.8 of ASCE 7.

**1608.9 Sliding snow.** The extra load caused by snow sliding off a sloped roof onto a lower roof shall be determined in accordance with Section 7.9 of ASCE 7.

**TABLE 1608.3.1  
SNOW EXPOSURE FACTOR,  $C_e$**

TERRAIN CATEGORY <sup>a</sup>	EXPOSURE OF ROOF <sup>a,b</sup>		
	Fully exposed <sup>c</sup>	Partially exposed	Sheltered
A (see Section 1609.4)	N/A	1.1	1.3
B (see Section 1609.4)	0.9	1.0	1.2
C (see Section 1609.4)	0.9	1.0	1.1
D (see Section 1609.4)	0.8	0.9	1.0
Above the treeline in windswept mountainous areas	0.7	0.8	N/A
In Alaska, in areas where trees do not exist within a 2-mile radius of the site	0.7	0.8	N/A

For SI: 1 mile = 1609 m.

- a. The terrain category and roof exposure condition chosen shall be representative of the anticipated conditions during the life of the structure. An exposure factor shall be determined for each roof of a structure.
- b. Definitions of roof exposure are as follows:
  - 1. Fully exposed shall mean roofs exposed on all sides with no shelter afforded by terrain, higher structures or trees. Roofs that contain several large pieces of mechanical equipment, parapets which extend above the height of the balanced snow load,  $h_b$ , or other obstructions are not in this category.
  - 2. Partially exposed shall include all roofs except those designated as “fully exposed” or “sheltered.”
  - 3. Sheltered roofs shall mean those roofs located tight in among conifers that qualify as “obstructions.”
- c. Obstructions within a distance of  $10 h_o$  provide “shelter,” where  $h_o$  is the height of the obstruction above the roof level. If the only obstructions are a few deciduous trees that are leafless in winter, the “fully exposed” category shall be used except for terrain category “A.” Note that these are heights above the roof. Heights used to establish the terrain category in Section 1609.4 are heights above the ground.

**TABLE 1608.3.2  
THERMAL FACTOR,  $C_t$**

THERMAL CONDITION <sup>a</sup>	$C_t$
All structures except as indicated below	1.0
Structures kept just above freezing and others with cold, ventilated roofs in which the thermal resistance ( $R$ -value) between the ventilated space and the heated space exceeds $25h \cdot \text{ft}^2 \cdot \text{°F/Btu}$	1.1
Unheated structures	1.2
Continuously heated greenhouses <sup>b</sup> with a roof having a thermal resistance ( $R$ -value) less than $2.0h \cdot \text{ft}^2 \cdot \text{°F/Btu}$	0.85

For SI:  $1 h \cdot \text{ft}^2 \cdot \text{°F/Btu} = 0.176 \text{ m}^2 \cdot \text{K/W}$ .

- a. The thermal condition shall be representative of the anticipated conditions during winters for the life of the structure.
- b. A continuously heated greenhouse shall mean a greenhouse with a constantly maintained interior temperature of 50°F or more during winter months. Such greenhouse shall also have a maintenance attendant on duty at all times or a temperature alarm system to provide warning in the event of a heating system failure.

**SECTION 1609  
WIND LOADS**

**1609.1 Applications.** Buildings, structures and parts thereof shall be designed to withstand the minimum wind loads prescribed herein. Decreases in wind loads shall not be made for the effect of shielding by other structures.

**1609.1.1 Determination of wind loads.** Wind loads on every building or structure shall be determined in accordance with Section 6 of ASCE 7. Wind shall be assumed to come from any horizontal direction and wind pressures shall be assumed to act normal to the surface considered.

**Exceptions:**

1. Wind loads determined by the provisions of Section 1609.6.
2. Subject to the limitations of Section 1609.1.1.1, the provisions of *SBCCI SSTD 10 Standard for Hurricane Resistant Residential Construction* shall be permitted for applicable Group R-2 and R-3 buildings.
3. Subject to the limitations of Section 1609.1.1.1, residential structures using the provisions of the *AF&PA Wood Frame Construction Manual for One- and Two-Family Dwellings*.
4. Designs using *NAAMM FP 1001 Guide Specification for Design of Metal Flagpoles*.
5. Designs using TIA/EIA-222 for antenna-supporting structures and antennas.

**1609.1.1.1 Applicability.** The provisions of SSTD 10 are applicable only to buildings located within Exposure B or C as defined in Section 1609.4. The provisions of SSTD 10 and the *AF&PA Wood Frame construction Manual for One- and Two-Family Dwellings* shall not apply to buildings sited on the upper half of an isolated hill, ridge or escarpment meeting the following conditions:

1. The hill, ridge or escarpment is 60 feet (18 288 mm) or higher if located in Exposure B or 30 feet (9144 mm) or higher if located in Exposure C;
2. The maximum average slope of the hill exceeds 10 percent; and
3. The hill, ridge or escarpment is unobstructed upwind by other such topographic features for a distance from the high point of 50 times the height of the hill or 1 mile (1.61 km), whichever is greater.

**1609.1.2 Minimum wind loads.** The wind loads used in the design of the main wind-force-resisting system shall not be less than 10 psf (0.479 kN/m<sup>2</sup>) multiplied by the area of the building or structure projected on a vertical plane normal to the wind direction. In the calculation of design wind loads for components and cladding for buildings, the algebraic sum of the pressures acting on opposite faces shall be taken into account. The design pressure for components and cladding of buildings shall not be less than 10 psf (0.479 kN/m<sup>2</sup>) acting in either direction normal to the surface. The design force for open buildings and other structures shall not be less than 10 psf (0.479 kN/m<sup>2</sup>) multiplied by the area  $A_p$ .

**1609.1.3 Anchorage against overturning, uplift and sliding.** Structural members and systems and components and cladding in a building or structure shall be anchored to resist wind-induced overturning, uplift and sliding and to provide continuous load paths for these forces to the foundation. Where a portion of the resistance to these forces is provided by dead load, the dead load, including the weight of soils and foundations, shall be taken as the minimum dead load likely to be in place during a design wind event. Where the alternate basic load combinations of Section 1605.3.2 are used, only two-thirds of the minimum dead load likely to be in place during a design wind event shall be used.

**1609.1.4 Protection of openings.** In wind-borne debris regions, glazing that receives positive external pressure in the lower 60 feet (18 288 mm) in buildings shall be assumed to be openings unless such glazing is impact resistant or protected with an impact-resistant covering meeting the requirements of an approved impact-resisting standard or ASTM E 1996 and of ASTM E 1886 referenced therein as follows:

1. Glazed openings located within 30 feet (9144 mm) of grade shall meet the requirements of the Large Missile Test of ASTM E 1996.
2. Glazed openings located more than 30 feet (9144 mm) above grade shall meet the provisions of the Small Missile Test of ASTM E 1996.

**Exceptions:**

1. Wood structural panels with a minimum thickness of  $7/16$  inch (11.1 mm) and maximum panel span of 8 feet (2438 mm) shall be permitted for opening protection in one- and two-story buildings. Panels shall be precut to cover the glazed openings with attachment hardware provided. Attachments shall be designed to resist the components and cladding loads determined in accordance with the provisions of Section 1609.6.1.2. Attachment in accordance with Table 1609.1.4 is permitted for buildings with a mean roof height of 33 feet (10 058 mm) or less where wind speeds do not exceed 130 mph (57.2 m/s).
2. Buildings in Category I as defined in Table 1604.5, including production greenhouses as defined in Section 1608.3.3.

**TABLE 1609.1.4  
WIND-BORNE DEBRIS PROTECTION FASTENING  
SCHEDULE FOR WOOD STRUCTURAL PANELS<sup>a,b,c</sup>**

FASTENER TYPE	FASTENER SPACING (inches)			
	Panel span ≤ 2 feet	2 feet < Panel span ≤ 4 feet	4 feet < Panel span ≤ 6 feet	6 feet < Panel span ≤ 8 feet
2 1/2 No. 6 Wood screws	16	16	12	9
2 1/2 No. 8 Wood screws	16	16	16	12

For SI: 1 inch = 25.4 mm, 1 foot = 304.8 mm, 1 pound = 4.4 N, 1 mile per hour = 0.44 m/s.

- a. This table is based on a maximum wind speed (3-second gust) of 130 mph and mean roof height of 33 feet or less.
- b. Fasteners shall be installed at opposing ends of the wood structural panel.
- c. Where screws are attached to masonry or masonry/stucco, they shall be attached utilizing vibration-resistant anchors having a minimum withdrawal capacity of 490 pounds.



**1609.1.4.1 Building with openings.** Where glazing is assumed to be an opening in accordance with Section 1609.1.4, the building shall be evaluated to determine if the openings are of sufficient area to constitute an open or partially enclosed building as defined in Section 1609.2. Open and partially enclosed buildings shall be designed in accordance with the applicable provisions of ASCE 7.

**1609.1.5 Wind and seismic detailing.** Lateral-force-resisting systems shall meet seismic detailing requirements and limitations prescribed in this code, even when wind code prescribed load effects are greater than seismic load effects.

**1609.2 Definitions.** The following words and terms shall, for the purposes of Section 1609.6, have the meanings shown herein.

**BUILDINGS AND OTHER STRUCTURES, FLEXIBLE.** Slender buildings and other structures that have a fundamental natural frequency less than 1 Hz.

**BUILDING, ENCLOSED.** A building that does not comply with the requirements for open or partially enclosed buildings.

**BUILDING, LOW-RISE.** Enclosed or partially enclosed buildings that comply with the following conditions:

1. Mean roof height,  $h$ , less than or equal to 60 feet (18 288 mm).
2. Mean roof height,  $h$ , does not exceed least horizontal dimension.

**BUILDING, OPEN.** A building having each wall at least 80 percent open. This condition is expressed for each wall by the equation:

$$A_o \geq 0.8 A_g \quad (\text{Equation 16-31})$$

where:

$A_o$  = Total area of openings in a wall that receives positive external pressure, in square feet ( $\text{m}^2$ ).

$A_g$  = The gross area of that wall in which  $A_o$  is identified, in square feet ( $\text{m}^2$ ).

**BUILDING, PARTIALLY ENCLOSED.** A building that complies with both of the following conditions:

1. The total area of openings in a wall that receives positive external pressure exceeds the sum of the areas of openings in the balance of the building envelope (walls and roof) by more than 10 percent; and
2. The total area of openings in a wall that receives positive external pressure exceeds 4 square feet ( $0.37 \text{ m}^2$ ) or 1 percent of the area of that wall, whichever is smaller, and the percentage of openings in the balance of the building envelope does not exceed 20 percent.

These conditions are expressed by the following equations:

$$A_o > 1.10 A_{oi} \quad (\text{Equation 16-32})$$

$$A_o > 4 \text{ square feet } (0.37 \text{ m}^2) \text{ or } > 0.01 A_g, \text{ whichever is smaller, and } A_{oi}/A_{gi} \leq 0.20 \quad (\text{Equation 16-33})$$

where:

$A_o$ ,  $A_g$  are as defined for an open building.

$A_{oi}$  = The sum of the areas of openings in the building envelope (walls and roof) not including  $A_o$ , in square feet ( $\text{m}^2$ ).

$A_{gi}$  = The sum of the gross surface areas of the building envelope (walls and roof) not including  $A_g$ , in square feet ( $\text{m}^2$ ).

**BUILDING, SIMPLE DIAPHRAGM.** A building in which wind loads are transmitted through floor and roof diaphragms to the vertical lateral-force-resisting systems.

**COMPONENTS AND CLADDING.** Elements of the building envelope that do not qualify as part of the main windforce-resisting system.

**EFFECTIVE WIND AREA.** The area used to determine  $GC_p$ . For component and cladding elements, the effective wind area in Tables 1609.6.2.1(2) and 1609.6.2.1(3) is the span length multiplied by an effective width that need not be less than one-third the span length. For cladding fasteners, the effective wind area shall not be greater than the area that is tributary to an individual fastener.

**HURRICANE-PRONE REGIONS.** Areas vulnerable to hurricanes defined as:

1. The U.S. Atlantic Ocean and Gulf of Mexico coasts where the basic wind speed is greater than 90 mph (39.6 m/s) and
2. Hawaii, Puerto Rico, Guam, Virgin Islands and American Samoa.

**IMPORTANCE FACTOR,  $I_w$ .** A factor that accounts for the degree of hazard to human life and damage to property.

**MAIN WINDFORCE-RESISTING SYSTEM.** An assemblage of structural elements assigned to provide support and stability for the overall structure. The system generally receives wind loading from more than one surface.

**MEAN ROOF HEIGHT.** The average of the roof eave height and the height to the highest point on the roof surface, except that eave height shall be used for roof angle of less than or equal to 10 degrees ( $0.1745 \text{ rad}$ ).

**WIND-BORNE DEBRIS REGION.** Areas within 1,500 feet (456 m) of the mean high water mark of the Atlantic Ocean.

**1609.3 Basic wind speed.** The basic wind speed, in mph, for the determination of the wind loads shall be determined by Figure 1609 or by ASCE 7 Figure 6-1 when using the provisions of ASCE 7. Basic wind speed for the special wind regions indicated, near mountainous terrain, and near gorges, shall be in accordance with local jurisdiction requirements. Basic wind speeds determined by the local jurisdiction shall be in accordance with Section 6.5.4 of ASCE 7.

In nonhurricane-prone regions, when the basic wind speed is estimated from regional climatic data, the basic wind speed shall be not less than the wind speed associated with an annual probability of 0.02 (50-year mean recurrence interval), and the estimate shall be adjusted for equivalence to a 3-second gust wind speed at 33 feet (10 m) above ground in exposure Category C. The data analysis shall be performed in accordance with Section 6.5.4 of ASCE 7.

**1609.3.1 Wind speed conversion.** When required, the 3-second gust wind velocities of Figure 1609 shall be converted to fastest-mile wind velocities using Table 1609.3.1.

**1609.4 Exposure category.** For each wind direction considered, an exposure category that adequately reflects the characteristics of ground surface irregularities shall be determined for the site at which the building or structure is to be constructed. For a site located in the transition zone between categories, the category resulting in the largest wind forces shall apply. Account shall be taken of variations in ground surface roughness that arise from natural topography and vegetation as well as from constructed features. For any given wind direction, the exposure in which a specific building or other structure is sited shall be assessed as being one of the following categories. When applying the simplified wind load method of Section 1609.6, a single exposure category shall be used based upon the most restrictive for any given wind direction.

1. **Exposure A.** This exposure category is no longer used in ASCE 7.
2. **Exposure B.** Urban and suburban areas, wooded areas or other terrain with numerous closely spaced obstructions having the size of single-family dwellings or larger. Exposure B shall be assumed unless the site meets the definition of another type of exposure.
3. **Exposure C.** Open terrain with scattered obstructions, including surface undulations or other irregularities, having heights generally less than 30 feet (9144 mm) extending more than 1,500 feet (457.2 m) from the building site in any quadrant. This exposure shall also apply to any building located within Exposure B-type terrain where the building is directly adjacent to open areas of Exposure C-type terrain in any quadrant for a distance of more than 600 feet (182.9 m). This category includes flat open country, grasslands and shorelines in hurricane-prone regions.
4. **Exposure D.** Flat, unobstructed areas exposed to wind flowing over open water (excluding shorelines in hurricane-prone regions) for a distance of at least 1 mile (1.61 km). Shorelines in Exposure D include inland waterways, the Great Lakes and coastal areas of California, Oregon, Washington and Alaska. This exposure shall apply only to those buildings and other structures exposed to the wind coming from over the water. Exposure D extends inland from the shoreline a distance of 1,500 feet (460 m) or 10 times the height of the building or structure, whichever is greater.

**1609.5 Importance factor.** Buildings and other structures shall be assigned a wind load importance factor,  $I_w$ , in accordance with Table 1604.5.

**1609.6 Simplified wind load method.**

**1609.6.1 Scope.** The procedures in Section 1609.6 shall be permitted to be used for determining and applying wind pressures in the design of enclosed buildings with flat, gabled and hipped roofs and having a mean roof height not exceeding the least horizontal dimension or 60 feet (18 288 mm), whichever is less, subject to the limitations of Sections 1609.6.1.1 and 1609.6.1.2. If a building qualifies only under Section 1609.6.1.2 for design of its components and cladding, then its main windforce-resisting system shall be designed in accordance with Section 1609.1.1.

**Exception:** The provisions of Section 1609.6 shall not apply to buildings sited on the upper half of an isolated hill or escarpment meeting all of the following conditions:

1. The hill or escarpment is 60 feet (18 288 mm) or higher if located in Exposure B or 30 feet (9144 mm) or higher if located in Exposure C.
2. The maximum average slope of the hill exceeds 10 percent.
3. The hill or escarpment is unobstructed upwind by other such topographic features for a distance from the high point of 50 times the height of the hill or 1 mile (1.61 km), whichever is less.

**1609.6.1.1 Main windforce-resisting systems.** For the design of main windforce-resisting systems, the building must meet all of the following conditions:

1. The building is a simple diaphragm building as defined in Section 1609.2.
2. The building is not classified as a flexible building as defined in Section 1609.2.
3. The building does not have response characteristics making it subject to across wind loading, vortex shedding, instability due to galloping or flutter; and does not have a site location for which channeling effects or buffeting in the wake of upwind obstructions warrant special consideration.
4. The building structure has no expansion joints or separations.
5. The building is regular shaped and has an approximately symmetrical cross section in each direction with roof slopes not exceeding 45 degrees (0.78 rad.).

**TABLE 1609.3.1**  
**EQUIVALENT BASIC WIND SPEEDS<sup>a,b,c</sup>**

$V_{3S}$	85	90	100	105	110	120	125	130	140	145	150	160	170
$V_{fm}$	70	75	80	85	90	100	105	110	120	125	130	140	150

For SI: 1 mile per hour = 0.44 m/s.

a. Linear interpolation is permitted.

b.  $V_{3S}$  is the 3-second gust wind speed (mph).

c.  $V_{fm}$  is the fastest mile wind speed (mph).

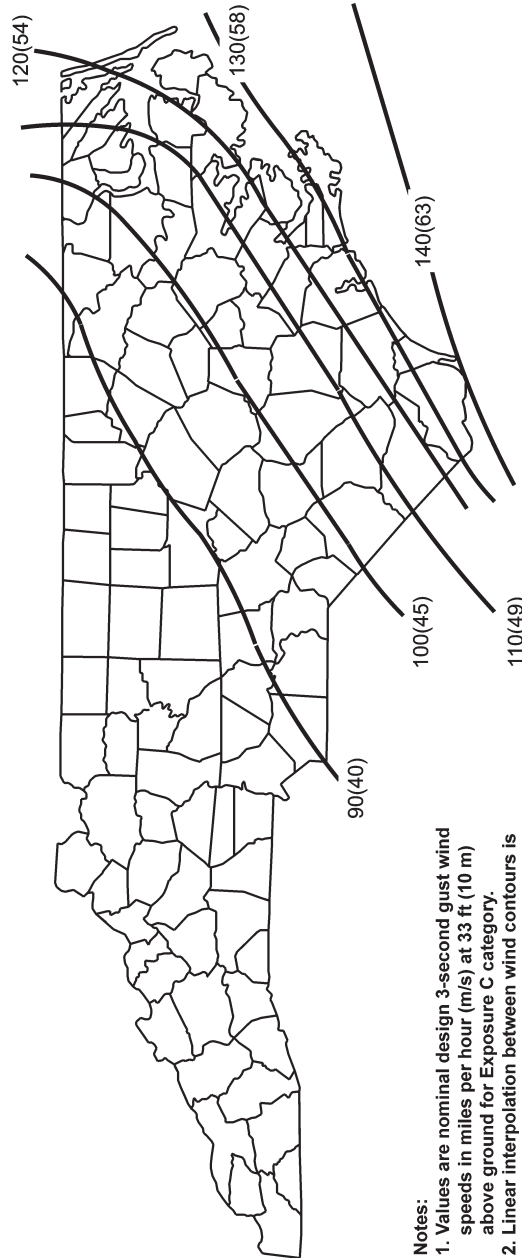

**Notes:**

1. Values are nominal design 3-second gust wind speeds in miles per hour (m/s) at 33 ft (10 m) above ground for Exposure C category.
2. Linear interpolation between wind contours is permitted.
3. Islands and coastal areas outside the last contour shall use the last wind speed contour of the coastal area.
4. Mountainous terrain, gorges, ocean promontories and special wind regions shall be examined for unusual wind conditions.

**FIGURE 1609  
NORTH CAROLINA BASIC WIND SPEED**

**1609.6.1.2 Components and cladding.** For the design of components and cladding, the building must meet all of the following conditions:

1. The building does not have response characteristics making it subject to across wind loading, vortex shedding, instability due to galloping or flutter; and does not have a site location for which channeling effects or buffeting in the wake of upwind obstructions warrant special consideration.
2. The building is regular shaped with roof slopes not exceeding 45 degrees (0.78 rad.) for gable roofs, or 27 degrees (0.47 rad.) for hip roofs.

**1609.6.2 Design procedure.**

1. The basic wind speed,  $V$ , shall be determined in accordance with Section 1609.3. The wind shall be assumed to come from any horizontal direction.
2. An importance factor  $I_w$  shall be determined in accordance with Section 1609.5.
3. An exposure category shall be determined in accordance with Section 1609.4.
4. A height and exposure adjustment coefficient,  $\lambda$ , shall be determined from Table 1609.6.2.1(4).

**1609.6.2.1 Main windforce-resisting system.** Simplified design wind pressures,  $p_s$ , for the main windforce-resisting systems represent the net pressures (sum of internal and external) to be applied to the horizontal and vertical projections of building surfaces as shown in Figure 1609.6.2.1. For the horizontal pressures (Zones A, B, C, D),  $p_s$  is the combination of the windward and leeward net pressures.  $p_s$  shall be determined from Equation 16-34).

$$p_s = \lambda I_w p_{s30} \tag{Equation 16-34}$$

where:

$\lambda$  = Adjustment factor for building height and exposure from Table 1609.6.2.1(4).

$I_w$  = Importance factor as defined in Section 1609.5

$p_{s30}$  = Simplified design wind pressure for Exposure B, at  $h = 30$  feet (9144 mm), and for  $I_w = 1.0$ , from Table 1609.6.2.1(1).

**1609.6.2.1.1 Minimum pressures.** The load effects of the design wind pressures from Section 1609.6.2.1 shall not be less than assuming the pressures,  $p_s$ , for Zones A, B, C and D all equal to +10 psf (0.48 kN/m<sup>2</sup>), while assuming Zones E, F, G, and H all equal to 0 psf.

**1609.6.2.2 Components and cladding.** Net design wind pressures,  $p_{net}$ , for the components and cladding of buildings represent the net pressures (sum of internal and external) to be applied normal to each building surface as shown in Figure 1609.6.2.2. The net design wind pressure,  $p_{net}$ , shall be determined from Equation 16-35:

$$p_{net} = \lambda I_w p_{net30} \tag{Equation 16-35}$$

where:

$\lambda$  = Adjustment factor for building height and exposure from Table 1609.6.2.1(4).

$I_w$  = Importance factor as defined in Section 1609.5.

$p_{net30}$  = Net design wind pressure for Exposure B, at  $h = 30$  feet (9144 mm), and for  $I_w = 1.0$ , from Tables 1609.6.2.1(2) and 1609.6.2.1(3).

**1609.6.2.2.1 Minimum pressures.** The positive design wind pressures,  $p_{net}$ , from Section 1609.6.2.2 shall not be less than +10 psf (0.48 kN/m<sup>2</sup>), and the negative design wind pressures,  $p_{net}$ , from Section 1609.6.2.2 shall not be less than -10 psf (-0.48 kN/m<sup>2</sup>).

**1609.6.2.3 Load case.** Members that act as both part of the main windforce-resisting system and as components and cladding shall be designed for each separate load case.

**1609.7 Roof systems.**

**1609.7.1 Roof deck.** The roof deck shall be designed to withstand the wind pressures determined under either the provisions of Section 1609.6 for buildings with a mean roof height not exceeding 60 feet (18 288 mm) or Section 1609.1.1 for buildings of any height.

**1609.7.2 Roof coverings.** Roof coverings shall comply with Section 1609.7.1.

**Exception:** Rigid tile roof coverings that are air permeable and installed over a roof deck complying with Section 1609.7.1 are permitted to be designed in accordance with Section 1609.7.3.



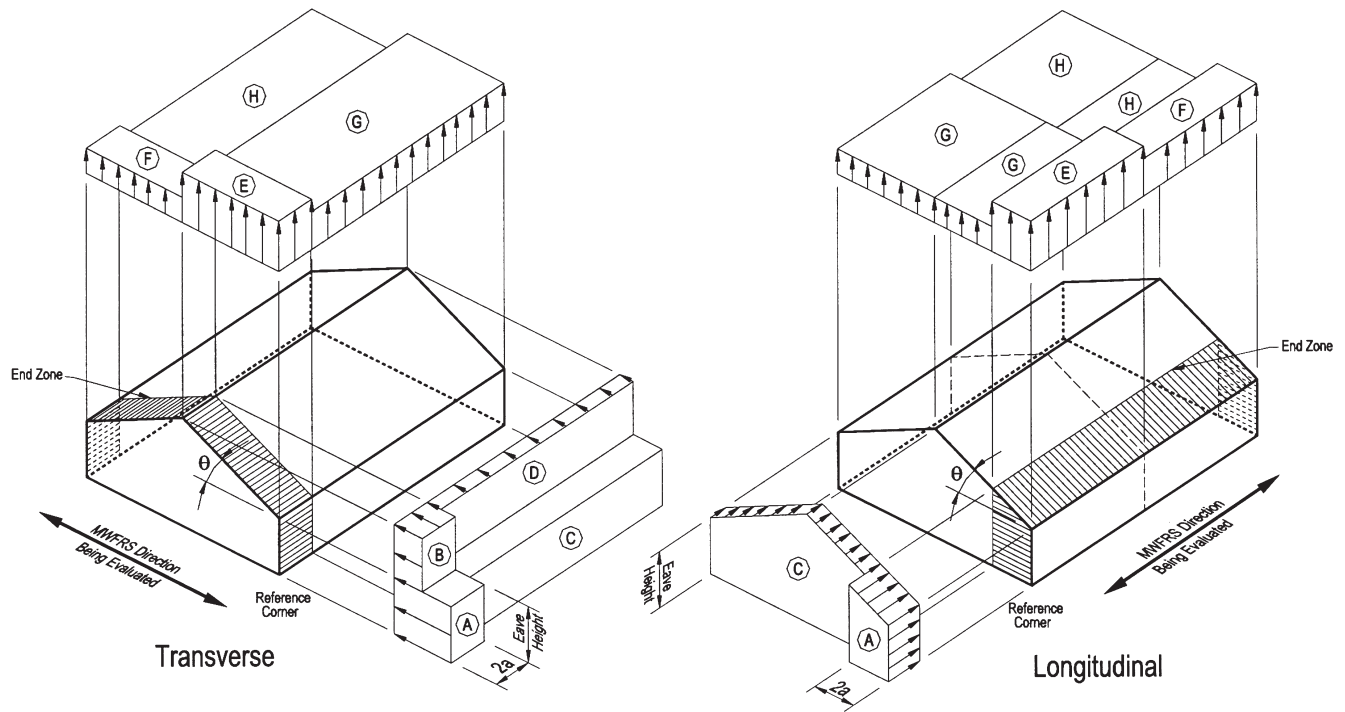

**FIGURE 1609.6.2.1**  
**MAIN WINDFORCE LOADING DIAGRAM**

For SI: 1 foot = 304.8 mm, 1 degree = 0.0174 rad.

**Notes:**

1. Pressures are applied to the horizontal and vertical projections for Exposure B, at  $h = 30$  feet, for  $I_w = 1.0$ . Adjust to other exposures and heights with adjustment factor  $\lambda$ .
2. The load patterns shown shall be applied to each corner of the building in turn as the reference corner.
3. For the design of the longitudinal MWFRS, use  $\theta = 0^\circ$ , and locate the Zone E/F, G/H boundary at the mid-length of the building.
4. Load Cases 1 and 2 must be checked for  $25^\circ < \theta \leq 45^\circ$ . Load Case 2 at  $25^\circ$  is provided only for interpolation between  $25^\circ$  to  $30^\circ$ .
5. Plus and minus signs signify pressures acting toward and away from the projected surfaces, respectively.
6. For roof slopes other than those shown, linear interpolation is permitted.
7. The total horizontal load shall not be less than that determined by assuming  $p_s = 0$  in Zones B and D.
8. The zone pressures represent the following:
  - Horizontal pressure zones — Sum of the windward and leeward net (sum of internal and external) pressures on vertical projection of:
 

A – End zone of wall	C – Interior zone of wall
B – End zone of roof	D – Interior zone of roof
  - Vertical pressure zones — Net (sum of internal and external) pressures on horizontal projection of:
 

E – End zone of windward roof	G – Interior zone of windward roof
F – End zone of leeward roof	H – Interior zone of leeward roof
9. Where Zone E or G falls on a roof overhang on the windward side of the building, use  $E_{OH}$  and  $G_{OH}$  for the pressure on the horizontal projection of the overhang. Overhangs on the leeward and side edges shall have the basic zone pressure applied.
10. Notation:
  - $a$ : 10 percent of least horizontal dimension or  $0.4h$ , whichever is smaller, but not less than either 4 percent of least horizontal dimension or 3 feet.
  - $h$ : Mean roof height, in feet (meters), except that eave height shall be used for roof angles  $< 10^\circ$ .
  - $\theta$ : Angle of plane of roof from horizontal, in degrees.

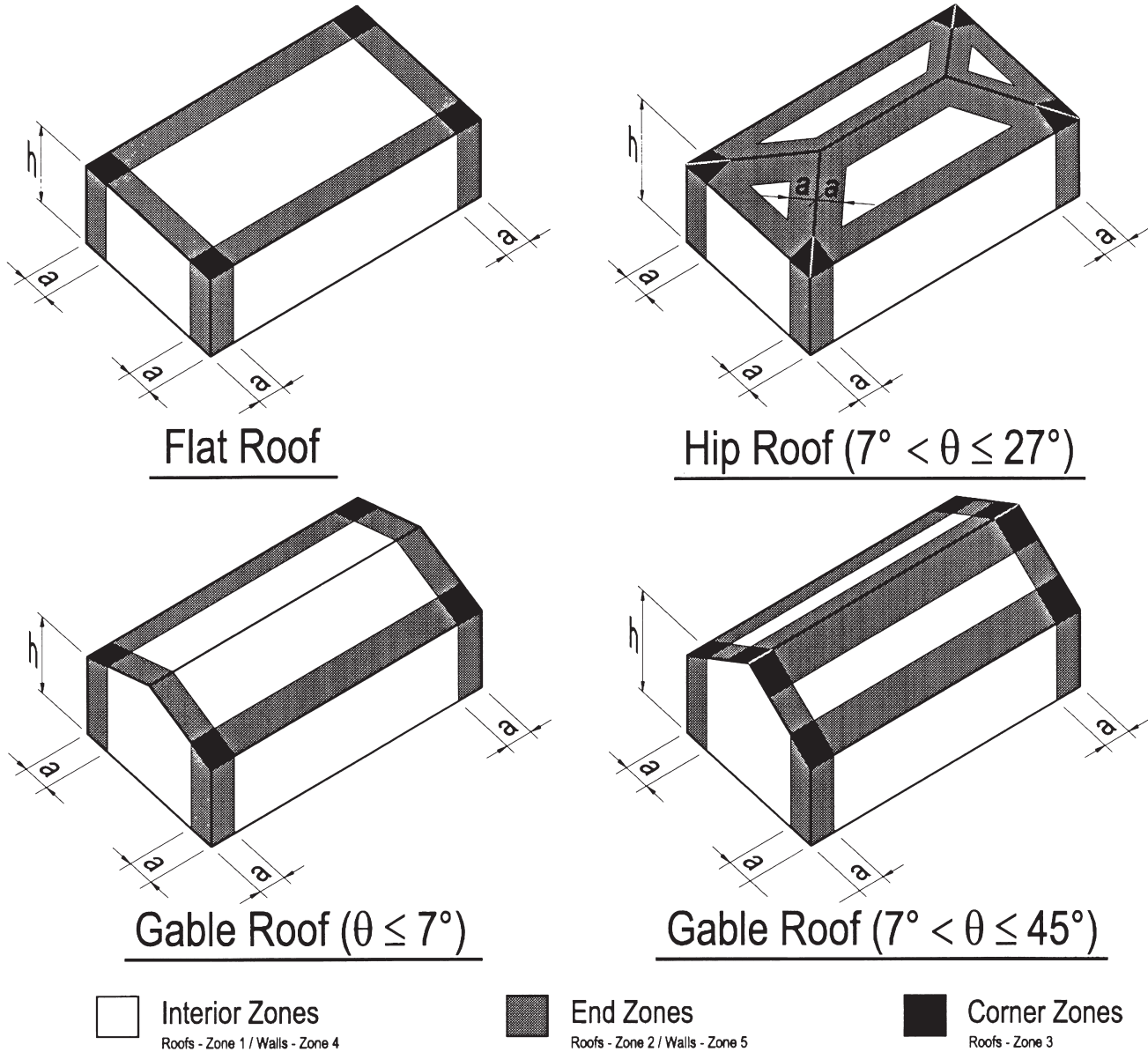

**FIGURE 1609.6.2.2  
COMPONENT AND CLADDING PRESSURE**

For SI: 1 foot = 304.8 mm, 1 degree = 0.0174 rad.

**Notes:**

1. Pressures are applied normal to the surface for Exposure B, at  $h = 30$  feet, for  $I_w = 1.0$ . Adjust to other exposures and heights with adjustment factor  $\lambda$ .
2. Plus and minus signs signify pressures acting toward and away from the surfaces, respectively.
3. For hip roofs with  $\theta \leq 25^\circ$ , Zone 3 shall be treated as Zone 2.
4. For effective areas between those given, the value is permitted to be interpolated, otherwise use the value associated with the lower effective area.
5. Notation:
  - $a$ : 10 percent of least horizontal dimension or  $0.4h$ , whichever is smaller, but not less than either 4 percent of least horizontal dimension or 3 feet.
  - $h$ : Mean roof height, in feet (meters), except that eave height shall be used for roof angles  $< 10^\circ$ .
  - $\theta$ : Angle of plane of roof from horizontal, in degrees.

TABLE 1609.6.2.1(1)  
SIMPLIFIED DESIGN WIND PRESSURE (MAIN WINDFORCE-RESISTING SYSTEM),  $p_{s30}$  (Exposure B at  $h = 30$  feet with  $I_w = 1.0$ ) (psf)

BASIC WIND SPEED (mph)	ROOF ANGLE (degrees)	ROOF RISE IN 12"	LOAD CASE	ZONES									
				Horizontal Pressures				Vertical Pressures				Overhangs	
				A	B	C	D	E	F	G	H	E <sub>OH</sub>	G <sub>OH</sub>
85	0 to 5°	Flat	1	11.5	-5.9	7.6	-3.5	-13.8	-7.8	-9.6	-6.1	-19.3	-15.1
	10°	2	1	12.9	-5.4	8.6	-3.1	-13.8	-8.4	-9.6	-6.5	-19.3	-15.1
	15°	3	1	14.4	-4.8	9.6	-2.7	-13.8	-9.0	-9.6	-6.9	-19.3	-15.1
	20°	4	1	15.9	-4.2	10.6	-2.3	-13.8	-9.6	-9.6	-7.3	-19.3	-15.1
	25°	6	1 2	14.4 —	2.3 —	10.4 —	2.4 —	-6.4 -2.4	-8.7 -4.7	-4.6 -0.7	-7.0 -3.0	-11.9 —	-10.1 —
	30° to 45°	7 to 12	1 2	12.9 12.9	8.8 8.8	10.2 10.2	7.0 7.0	1.0 5.0	-7.8 -3.9	0.3 4.3	-6.7 -2.8	-4.5 -4.5	-5.2 -5.2
90	0 to 5°	Flat	1	12.8	-6.7	8.5	-4.0	-15.4	-8.8	-10.7	-6.8	-21.6	-16.9
	10°	2	1	14.5	-6.0	9.6	-3.5	-15.4	-9.4	-10.7	-7.2	-21.6	-16.9
	15°	3	1	16.1	-5.4	10.7	-3.0	-15.4	-10.1	-10.7	-7.7	-21.6	-16.9
	20°	4	1	17.8	-4.7	11.9	-2.6	-15.4	-10.7	-10.7	-8.1	-21.6	-16.9
	25°	6	1 2	16.1 —	2.6 —	11.7 —	2.7 —	-7.2 -2.7	-9.8 -5.3	-5.2 -0.7	-7.8 -3.4	-13.3 —	-11.4 —
	30° to 45°	7 to 12	1 2	14.4 14.4	9.9 9.9	11.5 11.5	7.9 7.9	1.1 5.6	-8.8 -4.3	0.4 4.8	-7.5 -3.1	-5.1 -5.1	-5.8 -5.8
100	0 to 5°	Flat	1	15.9	-8.2	10.5	-4.9	-19.1	-10.8	-13.3	-8.4	-26.7	-20.9
	10°	2	1	17.9	-7.4	11.9	-4.3	-19.1	-11.6	-13.3	-8.9	-26.7	-20.9
	15°	3	1	19.9	-6.6	13.3	-3.8	-19.1	-12.4	-13.3	-9.5	-26.7	-20.9
	20°	4	1	22.0	-5.8	14.6	-3.2	-19.1	-13.3	-13.3	-10.1	-26.7	-20.9
	25°	6	1 2	19.9 —	3.2 —	14.4 —	3.3 —	-8.8 -3.4	-12.0 -6.6	-6.4 -0.9	-9.7 -4.2	-16.5 —	-14.0 —
	30° to 45°	7 to 12	1 2	17.8 17.8	12.2 12.2	14.2 14.2	9.8 9.8	1.4 6.9	-10.8 -5.3	0.5 5.9	-9.3 -3.8	-6.3 -6.3	-7.2 -7.2
110	0 to 5°	Flat	1	19.2	-10.0	12.7	-5.9	-23.1	-13.1	-16.0	-10.1	-32.3	-25.3
	10°	2	1	21.6	-9.0	14.4	-5.2	-23.1	-14.1	-16.0	-10.8	-32.3	-25.3
	15°	3	1	24.1	-8.0	16.0	-4.6	-23.1	-15.1	-16.0	-11.5	-32.3	-25.3
	20°	4	1	26.6	-7.0	17.7	-3.9	-23.1	-16.0	-16.0	-12.2	-32.3	-25.3
	25°	6	1 2	24.1 —	3.9 —	17.4 —	4.0 —	-10.7 -4.1	-14.6 -7.9	-7.7 -1.1	-11.7 -5.1	-19.9 —	-17.0 —
	30° to 45°	7 to 12	1 2	21.6 21.6	14.8 14.8	17.2 17.2	11.8 11.8	1.7 8.3	-13.1 -6.5	0.6 7.2	-11.3 -4.6	-7.6 -7.6	-8.7 -8.7
120	0 to 5°	Flat	1	22.8	-11.9	15.1	-7.0	-27.4	-15.6	-19.1	-12.1	-38.4	-30.1
	10°	2	1	25.8	-10.7	17.1	-6.2	-27.4	-16.8	-19.1	-12.9	-38.4	-30.1
	15°	3	1	28.7	-9.5	19.1	-5.4	-27.4	-17.9	-19.1	-13.7	-38.4	-30.1
	20°	4	1	31.6	-8.3	21.1	-4.6	-27.4	-19.1	-19.1	-14.5	-38.4	-30.1
	25°	6	1 2	28.6 —	4.6 —	20.7 —	4.7 —	-12.7 -4.8	-17.3 -9.4	-9.2 -1.3	-13.9 -6.0	-23.7 —	-20.2 —
	30° to 45°	7 to 12	1 2	25.7 25.7	17.6 17.6	20.4 20.4	14.0 14.0	2.0 9.9	-15.6 -7.7	0.7 8.6	-13.4 -5.5	-9.0 -9.0	-10.3 -10.3
130	0 to 5°	Flat	1	26.8	-13.9	17.8	-8.2	-32.2	-18.3	-22.4	-14.2	-45.1	-35.3
	10°	2	1	30.2	-12.5	20.1	-7.3	-32.2	-19.7	-22.4	-15.1	-45.1	-35.3
	15°	3	1	33.7	-11.2	22.4	-6.4	-32.2	-21.0	-22.4	-16.1	-45.1	-35.3
	20°	4	1	37.1	-9.8	24.7	-5.4	-32.2	-22.4	-22.4	-17.0	-45.1	-35.3
	25°	6	1 2	33.6 —	5.4 —	24.3 —	5.5 —	-14.9 -5.7	-20.4 -11.1	-10.8 -1.5	-16.4 -7.1	-27.8 —	-23.7 —
	30° to 45°	7 to 12	1 2	30.1 30.1	20.6 20.6	24.0 24.0	16.5 16.5	2.3 11.6	-18.3 -9.0	0.8 10.0	-15.7 -6.4	-10.6 -10.6	-12.1 -12.1

continued

**TABLE 1609.6.2.1(1)-continued**  
**SIMPLIFIED DESIGN WIND PRESSURE (MAIN WINDFORCE-RESISTING SYSTEM),  $p_{s30}$  (Exposure B at  $h = 30$  feet with  $I_w = 1.0$ ) (psf)**

BASIC WIND SPEED (mph)	ROOF ANGLE (degrees)	ROOF RISE IN 12"	LOAD CASE	ZONES									
				Horizontal Pressures				Vertical Pressures				Overhangs	
				A	B	C	D	E	F	G	H	$E_{OH}$	$G_{OH}$
140	0 to 5°	Flat	1	31.1	-16.1	20.6	-9.6	-37.3	-21.2	-26.0	-16.4	-52.3	-40.9
	10°	2	1	35.1	-14.5	23.3	-8.5	-37.3	-22.8	-26.0	-17.5	-52.3	-40.9
	15°	3	1	39.0	-12.9	26.0	-7.4	-37.3	-24.4	-26.0	-18.6	-52.3	-40.9
	20°	4	1	43.0	-11.4	28.7	-6.3	-37.3	-26.0	-26.0	-19.7	-52.3	-40.9
	25°	6	1 2	39.0 —	6.3 —	28.2 —	6.4 —	-17.3 -6.6	-23.6 -12.8	-12.5 -1.8	-19.0 -8.2	-32.3 —	-27.5 —
	30° to 45°	7 to 12	1 2	35.0 35.0	23.9 23.9	27.8 27.8	19.1 19.1	2.7 13.4	-21.2 -10.5	0.9 11.7	-18.2 -7.5	-12.3 -12.3	-14.0 -14.0
150	0 to 5°	Flat	1	35.7	-18.5	23.7	-11.0	-42.9	-24.4	-29.8	-18.9	-60.0	-47.0
	10°	2	1	40.2	-16.7	26.8	-9.7	-42.9	-26.2	-29.8	-20.1	-60.0	-47.0
	15°	3	1	44.8	-14.9	29.8	-8.5	-42.9	-28.0	-29.8	-21.4	-60.0	-47.0
	20°	4	1	49.4	-13.0	32.9	-7.2	-42.9	-29.8	-29.8	-22.6	-60.0	-47.0
	25°	6	1 2	44.8 —	7.2 —	32.4 —	7.4 —	-19.9 -7.5	-27.1 -14.7	-14.4 -2.1	-21.8 -9.4	-37.0 —	-31.6 —
	30° to 45°	7 to 12	1 2	40.1 40.1	27.4 27.4	31.9 31.9	22.0 22.0	3.1 15.4	-24.4 -12.0	1.0 13.4	-20.9 -8.6	-14.1 -14.1	-16.1 -16.1
170	0 to 5°	Flat	1	45.8	-23.8	30.4	-14.1	-55.1	-31.3	-38.3	-24.2	-77.1	-60.4
	10°	2	1	51.7	-21.4	34.4	-12.5	-55.1	-33.6	-38.3	-25.8	-77.1	-60.4
	15°	3	1	57.6	-19.1	38.3	-10.9	-55.1	-36.0	-38.3	-27.5	-77.1	-60.4
	20°	4	1	63.4	-16.7	42.3	-9.3	-55.1	-38.3	-38.3	-29.1	-77.1	-60.4
	25°	6	1 2	57.5 —	9.3 —	41.6 —	9.5 —	-25.6 -9.7	-34.8 -18.9	-18.5 -2.6	-28.0 -12.1	-47.6 —	-40.5 —
	30° to 45°	7 to 12	1 2	51.5 51.5	35.2 35.2	41.0 41.0	28.2 28.2	4.0 19.8	-31.3 -15.4	1.3 17.2	-26.9 -11.0	-18.1 -18.1	-20.7 -20.7

For SI: 1 inch = 25.4 mm, 1 foot = 304.8 mm, 1 degree = 0.0174 rad, 1 mile per hour = 0.44 m/s, 1 pound per square foot = 47.9 N/m<sup>2</sup>.



**TABLE 1609.6.2.1(2)**  
**NET DESIGN WIND PRESSURE (COMPONENT AND CLADDING),  $p_{net30}$  (Exposure B at  $h = 30$  feet with  $I_w = 1.0$ ) (psf)**

	ZONE	EFFECTIVE WIND AREA	BASIC WIND SPEED V (mph—3-second gust)																	
			85		90		100		110		120		130		140		150		170	
Roof 0 to 7 degrees	1	10	5.3	-13.0	5.9	-14.6	7.3	-18.0	8.9	-21.8	10.5	-25.9	12.4	-30.4	14.3	-35.3	16.5	-40.5	21.1	-52.0
	1	20	5.0	-12.7	5.6	-14.2	6.9	-17.5	8.3	-21.2	9.9	-25.2	11.6	-29.6	13.4	-34.4	15.4	-39.4	19.8	-50.7
	1	50	4.5	-12.2	5.1	-13.7	6.3	-16.9	7.6	-20.5	9.0	-24.4	10.6	-28.6	12.3	-33.2	14.1	-38.1	18.1	-48.9
	1	100	4.2	-11.9	4.7	-13.3	5.8	-16.5	7.0	-19.9	8.3	-23.7	9.8	-27.8	11.4	-32.3	13.0	-37.0	16.7	-47.6
	2	10	5.3	-21.8	5.9	-24.4	7.3	-30.2	8.9	-36.5	10.5	-43.5	12.4	-51.0	14.3	-59.2	16.5	-67.9	21.1	-87.2
	2	20	5.0	-19.5	5.6	-21.8	6.9	-27.0	8.3	-32.6	9.9	-38.8	11.6	-45.6	13.4	-52.9	15.4	-60.7	19.8	-78.0
	2	50	4.5	-16.4	5.1	-18.4	6.3	-22.7	7.6	-27.5	9.0	-32.7	10.6	-38.4	12.3	-44.5	14.1	-51.1	18.1	-65.7
	2	100	4.2	-14.1	4.7	-15.8	5.8	-19.5	7.0	-23.6	8.3	-28.1	9.8	-33.0	11.4	-38.2	13.0	-43.9	16.7	-56.4
	3	10	5.3	-32.8	5.9	-36.8	7.3	-45.4	8.9	-55.0	10.5	-65.4	12.4	-76.8	14.3	-89.0	16.5	-102.2	21.1	-131.3
	3	20	5.0	-27.2	5.6	-30.5	6.9	-37.6	8.3	-45.5	9.9	-54.2	11.6	-63.6	13.4	-73.8	15.4	-84.7	19.8	-108.7
	3	50	4.5	-19.7	5.1	-22.1	6.3	-27.3	7.6	-33.1	9.0	-39.3	10.6	-46.2	12.3	-53.5	14.1	-61.5	18.1	-78.9
	3	100	4.2	-14.1	4.7	-15.8	5.8	-19.5	7.0	-23.6	8.3	-28.1	9.8	-33.0	11.4	-38.2	13.0	-43.9	16.7	-56.4
Roof > 7 to 27 degrees	1	10	7.5	-11.9	8.4	-13.3	10.4	-16.5	12.5	-19.9	14.9	-23.7	17.5	-27.8	20.3	-32.3	23.3	-37.0	30.0	-47.6
	1	20	6.8	-11.6	7.7	-13.0	9.4	-16.0	11.4	-19.4	13.6	-23.0	16.0	-27.0	18.5	-31.4	21.3	-36.0	27.3	-46.3
	1	50	6.0	-11.1	6.7	-12.5	8.2	-15.4	10.0	-18.6	11.9	-22.2	13.9	-26.0	16.1	-30.2	18.5	-34.6	23.8	-44.5
	1	100	5.3	-10.8	5.9	-12.1	7.3	-14.9	8.9	-18.1	10.5	-21.5	12.4	-25.2	14.3	-29.3	16.5	-33.6	21.1	-43.2
	2	10	7.5	-20.7	8.4	-23.2	10.4	-28.7	12.5	-34.7	14.9	-41.3	17.5	-48.4	20.3	-56.2	23.3	-64.5	30.0	-82.8
	2	20	6.8	-19.0	7.7	-21.4	9.4	-26.4	11.4	-31.9	13.6	-38.0	16.0	-44.6	18.5	-51.7	21.3	-59.3	27.3	-76.2
	2	50	6.0	-16.9	6.7	-18.9	8.2	-23.3	10.0	-28.2	11.9	-33.6	13.9	-39.4	16.1	-45.7	18.5	-52.5	23.8	-67.4
	2	100	5.3	-15.2	5.9	-17.0	7.3	-21.0	8.9	-25.5	10.5	-30.3	12.4	-35.6	14.3	-41.2	16.5	-47.3	21.1	-60.8
	3	10	7.5	-30.6	8.4	-34.3	10.4	-42.4	12.5	-51.3	14.9	-61.0	17.5	-71.6	20.3	-83.1	23.3	-95.4	30.0	-122.5
	3	20	6.8	-28.6	7.7	-32.1	9.4	-39.6	11.4	-47.9	13.6	-57.1	16.0	-67.0	18.5	-77.7	21.3	-89.2	27.3	-114.5
	3	50	6.0	-26.0	6.7	-29.1	8.2	-36.0	10.0	-43.5	11.9	-51.8	13.9	-60.8	16.1	-70.5	18.5	-81.0	23.8	-104.0
	3	100	5.3	-24.0	5.9	-26.9	7.3	-33.2	8.9	-40.2	10.5	-47.9	12.4	-56.2	14.3	-65.1	16.5	-74.8	21.1	-96.0
Roof > 27 to 45 degrees	1	10	11.9	-13.0	13.3	-14.6	16.5	-18.0	19.9	-21.8	23.7	-25.9	27.8	-30.4	32.3	-35.3	37.0	-40.5	47.6	-52.0
	1	20	11.6	-12.3	13.0	-13.8	16.0	-17.1	19.4	-20.7	23.0	-24.6	27.0	-28.9	31.4	-33.5	36.0	-38.4	46.3	-49.3
	1	50	11.1	-11.5	12.5	-12.8	15.4	-15.9	18.6	-19.2	22.2	-22.8	26.0	-26.8	30.2	-31.1	34.6	-35.7	44.5	-45.8
	1	100	10.8	-10.8	12.1	-12.1	14.9	-14.9	18.1	-18.1	21.5	-21.5	25.2	-25.2	29.3	-29.3	33.6	-33.6	43.2	-43.2
	2	10	11.9	-15.2	13.3	-17.0	16.5	-21.0	19.9	-25.5	23.7	-30.3	27.8	-35.6	32.3	-41.2	37.0	-47.3	47.6	-60.8
	2	20	11.6	-14.5	13.0	-16.3	16.0	-20.1	19.4	-24.3	23.0	-29.0	27.0	-34.0	31.4	-39.4	36.0	-45.3	46.3	-58.1
	2	50	11.1	-13.7	12.5	-15.3	15.4	-18.9	18.6	-22.9	22.2	-27.2	26.0	-32.0	30.2	-37.1	34.6	-42.5	44.5	-54.6
	2	100	10.8	-13.0	12.1	-14.6	14.9	-18.0	18.1	-21.8	21.5	-25.9	25.2	-30.4	29.3	-35.3	33.6	-40.5	43.2	-52.0
	3	10	11.9	-15.2	13.3	-17.0	16.5	-21.0	19.9	-25.5	23.7	-30.3	27.8	-35.6	32.3	-41.2	37.0	-47.3	47.6	-60.8
	3	20	11.6	-14.5	13.0	-16.3	16.0	-20.1	19.4	-24.3	23.0	-29.0	27.0	-34.0	31.4	-39.4	36.0	-45.3	46.3	-58.1
	3	50	11.1	-13.7	12.5	-15.3	15.4	-18.9	18.6	-22.9	22.2	-27.2	26.0	-32.0	30.2	-37.1	34.6	-42.5	44.5	-54.6
	3	100	10.8	-13.0	12.1	-14.6	14.9	-18.0	18.1	-21.8	21.5	-25.9	25.2	-30.4	29.3	-35.3	33.6	-40.5	43.2	-52.0
Wall	4	10	13.0	-14.1	14.6	-15.8	18.0	-19.5	21.8	-23.6	25.9	-28.1	30.4	-33.0	35.3	-38.2	40.5	-43.9	52.0	-56.4
	4	20	12.4	-13.5	13.9	-15.1	17.2	-18.7	20.8	-22.6	24.7	-26.9	29.0	-31.6	33.7	-36.7	38.7	-42.1	49.6	-54.1
	4	50	11.6	-12.7	13.0	-14.3	16.1	-17.6	19.5	-21.3	23.2	-25.4	27.2	-29.8	31.6	-34.6	36.2	-39.7	46.6	-51.0
	4	100	11.1	-12.2	12.4	-13.6	15.3	-16.8	18.5	-20.4	22.0	-24.2	25.9	-28.4	30.0	-33.0	34.4	-37.8	44.2	-48.6
	4	500	9.7	-10.8	10.9	-12.1	13.4	-14.9	16.2	-18.1	19.3	-21.5	22.7	-25.2	26.3	-29.3	30.2	-33.6	38.8	-43.2
	5	10	13.0	-17.4	14.6	-19.5	18.0	-24.1	21.8	-29.1	25.9	-34.7	30.4	-40.7	35.3	-47.2	40.5	-54.2	52.0	-69.6
	5	20	12.4	-16.2	13.9	-18.2	17.2	-22.5	20.8	-27.2	24.7	-32.4	29.0	-38.0	33.7	-44.0	38.7	-50.5	49.6	-64.9
	5	50	11.6	-14.7	13.0	-16.5	16.1	-20.3	19.5	-24.6	23.2	-29.3	27.2	-34.3	31.6	-39.8	36.2	-45.7	46.6	-58.7
	5	100	11.1	-13.5	12.4	-15.1	15.3	-18.7	18.5	-22.6	22.0	-26.9	25.9	-31.6	30.0	-36.7	34.4	-42.1	44.2	-54.1
	5	500	9.7	-10.8	10.9	-12.1	13.4	-14.9	16.2	-18.1	19.3	-21.5	22.7	-25.2	26.3	-29.3	30.2	-33.6	38.8	-43.2

For SI: 1 foot = 304.8 mm, 1 degree = 0.0174 rad, 1 mile per hour = 0.44 m/s, 1 pound per square foot = 47.9 N/m<sup>2</sup>.

Note: For effective areas between those given above, the load is permitted to be interpolated, otherwise use the load associated with the lower effective area.

**TABLE 1609.6.2.1(3)**  
**ROOF OVERHANG NET DESIGN WIND PRESSURE (COMPONENT AND CLADDING),  $p_{net30}$  (Exposure B at  $h = 30$  feet with  $I_w = 1.0$ ) (psf)**

	ZONE	EFFECTIVE WIND AREA (sq. ft.)	BASIC WIND SPEED V (mph—3-second gust)							
			90	100	110	120	130	140	150	170
Roof 0 to 7 degrees	2	10	-21.0	-25.9	-31.4	-37.3	-43.8	-50.8	-58.3	-74.9
	2	20	-20.6	-25.5	-30.8	-36.7	-43.0	-49.9	-57.3	-73.6
	2	50	-20.1	-24.9	-30.1	-35.8	-42.0	-48.7	-55.9	-71.8
	2	100	-19.8	-24.4	-29.5	-35.1	-41.2	-47.8	-54.9	-70.5
	3	10	-34.6	-42.7	-51.6	-61.5	-72.1	-83.7	-96.0	-123.4
	3	20	-27.1	-33.5	-40.5	-48.3	-56.6	-65.7	-75.4	-96.8
	3	50	-17.3	-21.4	-25.9	-30.8	-36.1	-41.9	-48.1	-61.8
	3	100	-10.0	-12.2	-14.8	-17.6	-20.6	-23.9	-27.4	-35.2
Roof > 7 to 27 degrees	2	10	-27.2	-33.5	-40.6	-48.3	-56.7	-65.7	-75.5	-96.9
	2	20	-27.2	-33.5	-40.6	-48.3	-56.7	-65.7	-75.5	-96.9
	2	50	-27.2	-33.5	-40.6	-48.3	-56.7	-65.7	-75.5	-96.9
	2	100	-27.2	-33.5	-40.6	-48.3	-56.7	-65.7	-75.5	-96.9
	3	10	-45.7	-56.4	-68.3	-81.2	-95.3	-110.6	-126.9	-163.0
	3	20	-41.2	-50.9	-61.6	-73.3	-86.0	-99.8	-114.5	-147.1
	3	50	-35.3	-43.6	-52.8	-62.8	-73.7	-85.5	-98.1	-126.1
	3	100	-30.9	-38.1	-46.1	-54.9	-64.4	-74.7	-85.8	-110.1
Roof > 27 to 45 degrees	2	10	-24.7	-30.5	-36.9	-43.9	-51.5	-59.8	-68.6	-88.1
	2	20	-24.0	-29.6	-35.8	-42.6	-50.0	-58.0	-66.5	-85.5
	2	50	-23.0	-28.4	-34.3	-40.8	-47.9	-55.6	-63.8	-82.0
	2	100	-22.2	-27.4	-33.2	-39.5	-46.4	-53.8	-61.7	-79.3
	3	10	-24.7	-30.5	-36.9	-43.9	-51.5	-59.8	-68.6	-88.1
	3	20	-24.0	-29.6	-35.8	-42.6	-50.0	-58.0	-66.5	-85.5
	3	50	-23.0	-28.4	-34.3	-40.8	-47.9	-55.5	-63.8	-82.2
	3	100	-22.2	-27.4	-33.2	-39.5	-46.4	-53.8	-61.7	-79.3

For SI: 1 foot = 304.8 mm, 1 degree = 0.0174 rad, 1 mile per hour = 0.45 m/s, 1 pound per square foot = 47.9 N/m<sup>2</sup>.

**Note:** For effective areas between those given above, the load is permitted to be interpolated, otherwise use the load associated with the lower effective area.

**TABLE 1609.6.2.1(4)**  
**ADJUSTMENT FACTOR FOR BUILDING HEIGHT AND EXPOSURE, ( $\lambda$ )**

MEAN ROOF HEIGHT (feet)	EXPOSURE		
	B	C	D
15	1.00	1.21	1.47
20	1.00	1.29	1.55
25	1.00	1.35	1.61
30	1.00	1.40	1.66
35	1.05	1.45	1.70
40	1.09	1.49	1.74
45	1.12	1.53	1.78
50	1.16	1.56	1.81
55	1.19	1.59	1.84
60	1.22	1.62	1.87

For SI: 1 foot = 304.8 mm.

a. All table values shall be adjusted for other exposures and heights by multiplying by the above coefficients.

**1609.7.3 Rigid tile.** Wind loads on rigid tile roof coverings shall be determined in accordance with the following equation:

$$M_a = q_h C_L b L L_a [1.0 - GC_p] \quad \text{(Equation 16-36)}$$

$$\text{For SI: } M_a = \frac{q_h C_L b L L_a [1.0 - GC_p]}{1,000}$$

where:

- $b$  = Exposed width, feet (mm) of the roof tile.
- $C_L$  = Lift coefficient. The lift coefficient for concrete and clay tile shall be 0.2 or shall be determined by test in accordance with Section 1715.2.
- $GC_p$  = Roof pressure coefficient for each applicable roof zone determined from Section 6 of ASCE 7. Roof coefficients shall not be adjusted for internal pressure.
- $L$  = Length, feet (mm) of the roof tile.
- $L_a$  = Moment arm, feet (mm) from the axis of rotation to the point of uplift on the roof tile. The point of uplift shall be taken at  $0.76L$  from the head of the tile and the middle of the exposed width. For roof tiles with nails or screws (with or without a tail clip), the axis of rotation shall be taken as the head of the tile for direct application or as the top edge of the batten for battened applications. For roof tiles fastened only by a nail or screw along the side of the tile, the axis of rotation shall be determined by testing. For roof tiles installed with battens and fastened only by a clip near the tail of the tile, the moment arm shall be determined about the top edge of the batten with consideration given for the point of rotation of the tiles based on straight bond or broken bond and the tile profile.
- $M_a$  = Aerodynamic uplift moment, feet-pounds (N-mm) acting to raise the tail of the tile.
- $q_h$  = Wind velocity pressure, psf (kN/m<sup>2</sup>) determined from Section 6.5.10 of ASCE 7.

Concrete and clay roof tiles complying with the following limitations shall be designed to withstand the aerodynamic uplift moment as determined by this section.

1. The roof tiles shall be either loose laid on battens, mechanically fastened, mortar set or adhesive set.
2. The roof tiles shall be installed on solid sheathing which has been designed as components and cladding.
3. An underlayment shall be installed in accordance with Chapter 15.
4. The tile shall be single lapped interlocking with a minimum head lap of not less than 2 inches (51 mm).
5. The length of the tile shall be between 1.0 and 1.75 feet (305 mm and 533 mm).
6. The exposed width of the tile shall be between 0.67 and 1.25 feet (204 mm and 381 mm).

7. The maximum thickness of the tail of the tile shall not exceed 1.3 inches (33 mm).
8. Roof tiles using mortar set or adhesive set systems shall have at least two-thirds of the tile's area free of mortar or adhesive contact.

### SECTION 1610 SOIL LATERAL LOAD

**1610.1 General.** Basement, foundation and retaining walls shall be designed to resist lateral soil loads. Soil loads specified in Table 1610.1 shall be used as the minimum design lateral soil loads unless specified otherwise in a soil investigation report approved by the building official. Basement walls and other walls in which horizontal movement is restricted at the top shall be designed for at-rest pressure. Retaining walls free to move and rotate at the top are permitted to be designed for active pressure. Design lateral pressure from surcharge loads shall be added to the lateral earth pressure load. Design lateral pressure shall be increased if soils with expansion potential are present at the site.

**Exception:** Basement walls extending not more than 8 feet (2438 mm) below grade and supporting flexible floor systems shall be permitted to be designed for active pressure.

### SECTION 1611 RAIN LOADS

**1611.1 Design rain loads.** Each portion of a roof shall be designed to sustain the load of rainwater that will accumulate on it if the primary drainage system for that portion is blocked plus the uniform load caused by water that rises above the inlet of the secondary drainage system at its design flow.

$$R = 5.2 (d_s + d_h) \quad \text{(Equation 16-37)}$$

$$\text{For SI: } R = 0.0098 (d_s + d_h)$$

where:

- $d_h$  = Additional depth of water on the undeflected roof above the inlet of secondary drainage system at its design flow (i.e., the hydraulic head), in inches (mm).
- $d_s$  = Depth of water on the undeflected roof up to the inlet of secondary drainage system when the primary drainage system is blocked (i.e., the static head), in inches (mm).
- $R$  = Rain load on the undeflected roof, in psf (kN/m<sup>2</sup>). When the phrase "undeflected roof" is used, deflections from loads (including dead loads) shall not be considered when determining the amount of rain on the roof.

**1611.2 Ponding instability.** Ponding refers to the retention of water due solely to the deflection of relatively flat roofs. Roofs with a slope less than one-fourth unit vertical in 12 units horizontal (2-percent slope) shall be investigated by structural analysis to ensure that they possess adequate stiffness to preclude progressive deflection (i.e., instability) as rain falls on them or meltwater is created from snow on them. The larger of snow load or rain load shall be used in this analysis. The primary drainage system within an area subjected to ponding shall be considered to be blocked in this analysis.

**TABLE 1610.1  
SOIL LATERAL LOAD**

DESCRIPTION OF BACKFILL MATERIAL <sup>c</sup>	UNIFIED SOIL CLASSIFICATION	DESIGN LATERAL SOIL LOAD <sup>a</sup> (pound per square foot per foot of depth)	
		Active pressure	At-rest pressure
Well-graded, clean gravels; gravel-sand mixes	GW	30	60
Poorly graded clean gravels; gravel-sand mixes	GP	30	60
Silty gravels, poorly graded gravel-sand mixes	GM	40	60
Clayey gravels, poorly graded gravel-and-clay mixes	GC	45	60
Well-graded, clean sands; gravelly sand mixes	SW	30	60
Poorly graded clean sands; sand-gravel mixes	SP	30	60
Silty sands, poorly graded sand-silt mixes	SM	45	60
Sand-silt clay mix with plastic fines	SM-SC	45	100
Clayey sands, poorly graded sand-clay mixes	SC	60	100
Inorganic silts and clayey silts	ML	45	100
Mixture of inorganic silt and clay	ML-CL	60	100
Inorganic clays of low to medium plasticity	CL	60	100
Organic silts and silt clays, low plasticity	OL	Note b	Note b
Inorganic clayey silts, elastic silts	MH	Note b	Note b
Inorganic clays of high plasticity	CH	Note b	Note b
Organic clays and silty clays	OH	Note b	Note b

For SI: 1 pound per square foot per foot of depth = 0.157 kPa/m, 1 foot = 304.8 mm.

- a. Design lateral soil loads are given for moist conditions for the specified soils at their optimum densities. Actual field conditions shall govern. Submerged or saturated soil pressures shall include the weight of the buoyant soil plus the hydrostatic loads.
- b. Unsuitable as backfill material.
- c. The definition and classification of soil materials shall be in accordance with ASTM D 2487.

**1611.3 Controlled drainage.** Roofs equipped with hardware to control the rate of drainage shall be equipped with a secondary drainage system at a higher elevation that limits accumulation of water on the roof above that elevation. Such roofs shall be designed to sustain the load of rainwater that will accumulate on them to the elevation of the secondary drainage system plus the uniform load caused by water that rises above the inlet of the secondary drainage system at its design flow determined from Section 1611.1. Such roofs shall also be checked for ponding instability in accordance with Section 1611.2.

**SECTION 1612  
FLOOD LOADS**

**1612.1 General.** Within flood hazard areas as established in Section 1612.3, all new construction of buildings, structures and portions of buildings and structures, including substantial improvements and restoration of substantial damage to buildings and structures, shall be designed and constructed to resist the effects of flood hazards and flood loads. For construction in coastal high hazard areas and ocean high hazard areas see Section 1624.

**1612.2 Definitions.** The following words and terms shall, for the purposes of this section, have the meanings shown herein.

**BASE FLOOD.** The flood having a 1-percent chance of being equaled or exceeded in any given year.

**BASE FLOOD ELEVATION.** The elevation of the base flood, including wave height, relative to the National Geodetic Vertical Datum (NGVD), North American Vertical Datum (NAVD) or other datum specified on the Flood Insurance Rate Map (FIRM).

**BASEMENT.** The portion of a building having its floor subgrade (below ground level) on all sides.

**DESIGN FLOOD.** The flood associated with the greater of the following two areas:

1. Area with a flood plain subject to a 1-percent or greater chance of flooding in any year; or
2. Area designated as a flood hazard area on a community’s flood hazard map, or otherwise legally designated.

**DESIGN FLOOD ELEVATION.** The elevation of the “design flood,” including wave height, relative to the datum specified on the community’s legally designated flood hazard map. In areas designated as Zone AO, the design flood elevation shall be the elevation of the highest existing grade of the building’s perimeter plus the depth number (in feet) specified on the flood hazard map. In areas designated as Zone AO where a depth number is not specified on the map, the depth number shall be taken as being equal to 2 feet (610 mm).

**DRY FLOODPROOFING.** A combination of design modifications that results in a building or structure, including the attendant utility and sanitary facilities, being water tight with



walls substantially impermeable to the passage of water and with structural components having the capacity to resist loads as identified in ASCE 7.

**EXISTING CONSTRUCTION.** Any buildings and structures for which the “start of construction” commenced before the effective date of the community’s first flood plain management code, ordinance or standard. “Existing construction” is also referred to as “existing structures.”

**EXISTING STRUCTURE.** See “Existing construction.”

**FLOOD or FLOODING.** A general and temporary condition of partial or complete inundation of normally dry land from:

1. The overflow of inland or tidal waters.
2. The unusual and rapid accumulation or runoff of surface waters from any source.

**FLOOD DAMAGE-RESISTANT MATERIALS.** Any construction material capable of withstanding direct and prolonged contact with floodwaters without sustaining any damage that requires more than cosmetic repair.

**FLOOD HAZARD AREA.** The greater of the following two areas:

1. The area within a flood plain subject to a 1-percent or greater chance of flooding in any year.
2. The area designated as a flood hazard area on a community’s flood hazard map, or otherwise legally designated.

**FLOOD HAZARD AREA SUBJECT TO HIGH VELOCITY WAVE ACTION.** Area within the flood hazard area that is subject to high velocity wave action, and shown on a Flood Insurance Rate Map (FIRM) or other flood hazard map as Zone V, VO, VE or V1-30.

**FLOOD INSURANCE RATE MAP (FIRM).** An official map of a community on which the Federal Emergency Management Agency (FEMA) has delineated both the special flood hazard areas and the risk premium zones applicable to the community.

**FLOOD INSURANCE STUDY.** The official report provided by the Federal Emergency Management Agency containing the Flood Insurance Rate Map (FIRM), the Flood Boundary and Floodway Map (FBFM), the water surface elevation of the base flood and supporting technical data.

**FLOODWAY.** The channel of the river, creek or other watercourse and the adjacent land areas that must be reserved in order to discharge the base flood without cumulatively increasing the water surface elevation more than a designated height.

**LOWEST FLOOR.** The floor of the lowest enclosed area, including basement, but excluding any unfinished or flood-resistant enclosure, usable solely for vehicle parking, building access or limited storage provided that such enclosure is not built so as to render the structure in violation of this section.

**SPECIAL FLOOD HAZARD AREA.** The land area subject to flood hazards and shown on a Flood Insurance Rate Map or other flood hazard map as Zone A, AE, A1-30, A99, AR, AO, AH, V, VO, VE or V1-30.

**START OF CONSTRUCTION.** The date of permit issuance for new construction and substantial improvements to existing structures, provided the actual start of construction, repair, reconstruction, rehabilitation, addition, placement or other improvement is within 180 days after the date of issuance. The actual start of construction means the first placement of permanent construction of a building (including a manufactured home) on a site, such as the pouring of a slab or footings, installation of pilings or construction of columns.

Permanent construction does not include land preparation (such as clearing, excavation, grading or filling), the installation of streets or walkways, excavation for a basement, footings, piers or foundations, the erection of temporary forms or the installation of accessory buildings such as garages or sheds not occupied as dwelling units or not part of the main building. For a substantial improvement, the actual “start of construction” means the first alteration of any wall, ceiling, floor or other structural part of a building, whether or not that alteration affects the external dimensions of the building.

**SUBSTANTIAL DAMAGE.** Damage of any origin sustained by a structure whereby the cost of restoring the structure to its before-damaged condition would equal or exceed 50 percent of the market value of the structure before the damage occurred.

**SUBSTANTIAL IMPROVEMENT.** Any repair, reconstruction, rehabilitation, addition or improvement of a building or structure, the cost of which equals or exceeds 50 percent of the market value of the structure before the improvement or repair is started. If the structure has sustained substantial damage, any repairs are considered substantial improvement regardless of the actual repair work performed. The term does not, however, include either:

1. Any project for improvement of a building required to correct existing health, sanitary or safety code violations identified by the building official and that are the minimum necessary to assure safe living conditions.
2. Any alteration of a historic structure provided that the alteration will not preclude the structure’s continued designation as a historic structure.

**1612.3 Establishment of flood hazard areas.** To establish flood hazard areas, the governing body shall adopt a flood hazard map and supporting data. The flood hazard map shall include, at a minimum, areas of special flood hazard as identified by the Federal Emergency Management Agency in an engineering report entitled “The Flood Insurance Study for [INSERT NAME OF JURISDICTION],” dated [INSERT DATE OF ISSUANCE], as amended or revised with the accompanying Flood Insurance Rate Map (FIRM) and Flood Boundary and Floodway Map (FBFM) and related supporting data along with any revisions thereto. The adopted flood hazard map and supporting data are hereby adopted by reference and declared to be part of this section.

**1612.4 Design and construction.** The design and construction of buildings and structures located in flood hazard areas, including flood hazard areas subject to high velocity wave action, shall be in accordance with ASCE 24.

**1612.5 Flood hazard documentation.** The following documentation shall be prepared and sealed by a registered design professional and submitted to the building official:

1. For construction in flood hazard areas not subject to high-velocity wave action:
  - 1.1. The elevation of the lowest floor, including basement, as required by the lowest floor elevation inspection in Section 109.3.3.
  - 1.2. For fully enclosed areas below the design flood elevation where provisions to allow for the automatic entry and exit of floodwaters do not meet the minimum requirements in Section 2.6.1.1, ASCE 24, construction documents shall include a statement that the design will provide for equalization of hydrostatic flood forces in accordance with Section 2.6.1.2, ASCE 24.
  - 1.3. For dry floodproofed nonresidential buildings, construction documents shall include a statement that the dry floodproofing is designed in accordance with ASCE 24.
2. For construction in flood hazard areas subject to high-velocity wave action:
  - 2.1. The elevation of the bottom of the lowest horizontal structural member as required by the lowest floor elevation inspection in Section 109.3.3.
  - 2.2. Construction documents shall include a statement that the building is designed in accordance with ASCE 24, including that the pile or column foundation and building or structure to be attached thereto is designed to be anchored to resist flotation, collapse and lateral movement due to the effects of wind and flood loads acting simultaneously on all building components, and other load requirements of Chapter 16.
  - 2.3. For breakaway walls designed to resist a nominal load of less than 10 psf (0.48 kN/m<sup>2</sup>) or more than 20 psf (0.96 kN/m<sup>2</sup>), construction documents shall include a statement that the breakaway wall is designed in accordance with ASCE 24.

## SECTION 1613 EARTHQUAKE LOADS DEFINITIONS

**1613.1 Definitions.** The following words and terms shall, for the purposes of this section, have the meanings shown herein.

**ACTIVE FAULT/ACTIVE FAULT TRACE.** A fault for which there is an average historic slip rate of 1 mm per year or more and geologic evidence of seismic activity within Holocene (past 11,000 years) times. Active fault traces are designated by the appropriate regulatory agency and/or registered design professional subject to identification by a geologic report.

**ATTACHMENTS, SEISMIC.** Means by which components and their supports are secured or connected to the seismic-force-resisting system of the structure. Such attachments

include anchor bolts, welded connections and mechanical fasteners.

**BASE.** The level at which the horizontal seismic ground motions are considered to be imparted to the structure.

**BOUNDARY ELEMENTS.** Chords and collectors at diaphragm and shear wall edges, interior openings, discontinuities and reentrant corners.

**BRITTLE.** Systems, members, materials and connections that do not exhibit significant energy dissipation capacity in the inelastic range.

**COLLECTOR.** A diaphragm or shear wall element parallel to the applied load that collects and transfers shear forces to the vertical-force-resisting elements or distributes forces within a diaphragm or shear wall.

**COMPONENT.** A part or element of an architectural, electrical, mechanical or structural system.

**Component, equipment.** A mechanical or electrical component or element that is part of a mechanical and/or electrical system within or without a building system.

**Component, flexible.** Component, including its attachments, having a fundamental period greater than 0.06 second.

**Component, rigid.** Component, including its attachments, having a fundamental period less than or equal to 0.06 second.

**DESIGN EARTHQUAKE.** The earthquake effects that buildings and structures are specifically proportioned to resist in Sections 1613 through 1622.

**DESIGNATED SEISMIC SYSTEM.** Those architectural, electrical and mechanical systems and their components that require design in accordance with Section 1621 that have a component importance factor,  $I_p$ , greater than one.

### DISPLACEMENT.

**Design displacement.** The design earthquake lateral displacement, excluding additional displacement due to actual and accidental torsion, required for design of the isolation system.

**Total design displacement.** The design earthquake lateral displacement, including additional displacement due to actual and accidental torsion, required for design of the isolation system.

**Total maximum displacement.** The maximum considered earthquake lateral displacement, including additional displacement due to actual and accidental torsion, required for verification of the stability of the isolation system or elements thereof, design of building separations and vertical load testing of isolator unit prototype.

**DISPLACEMENT RESTRAINT SYSTEM.** A collection of structural elements that limits lateral displacement of seismically isolated structures due to the maximum considered earthquake.

**EFFECTIVE DAMPING.** The value of equivalent viscous damping corresponding to energy dissipated during cyclic response of the isolation system.

**EFFECTIVE STIFFNESS.** The value of the lateral force in the isolation system, or an element thereof, divided by the corresponding lateral displacement.

**HAZARDOUS CONTENTS.** A material that is highly toxic or potentially explosive and in sufficient quantity to pose a significant life-safety threat to the general public if an uncontrolled release were to occur.

**INVERTED PENDULUM-TYPE STRUCTURES.** Structures that have a large portion of their mass concentrated near the top, and thus have essentially one degree of freedom in horizontal translation. The structures are usually T-shaped with a single column supporting the beams or framing at the top.

**ISOLATION INTERFACE.** The boundary between the upper portion of the structure, which is isolated, and the lower portion of the structure, which moves rigidly with the ground.

**ISOLATION SYSTEM.** The collection of structural elements that includes individual isolator units, structural elements that transfer force between elements of the isolation system and connections to other structural elements.

**ISOLATOR UNIT.** A horizontally flexible and vertically stiff structural element of the isolation system that permits large lateral deformations under design seismic load. An isolator unit is permitted to be used either as part of or in addition to the weight-supporting system of the building.

#### **LOAD.**

**Gravity load ( $W$ ).** The total dead load and applicable portions of other loads as defined in Sections 1613 through 1622.

**MAXIMUM CONSIDERED EARTHQUAKE.** The most severe earthquake effects considered by this code.

**NONBUILDING STRUCTURE.** A structure, other than a building, constructed of a type included in Section 1622.

**OCCUPANCY IMPORTANCE FACTOR.** A factor assigned to each structure according to its seismic use group as prescribed in Table 1604.5.

**SEISMIC DESIGN CATEGORY.** A classification assigned to a structure based on its seismic use group and the severity of the design earthquake ground motion at the site.

**SEISMIC-FORCE-RESISTING SYSTEM.** The part of the structural system that has been considered in the design to provide the required resistance to the seismic forces prescribed herein.

**SEISMIC FORCES.** The assumed forces prescribed herein, related to the response of the structure to earthquake motions, to be used in the design of the structure and its components.

**SEISMIC USE GROUP.** A classification assigned to a building based on its use as defined in Section 1616.2.

**SHEAR WALL.** A wall designed to resist lateral forces parallel to the plane of the wall.

**SHEAR WALL-FRAME INTERACTIVE SYSTEM.** A structural system that uses combinations of shear walls and frames designed to resist lateral forces in proportion to their rigidities, considering interaction between shear walls and frames on all levels.

**SITE CLASS.** A classification assigned to a site based on the types of soils present and their engineering properties as defined in Section 1615.1.5.

**SITE COEFFICIENTS.** The values of  $F_a$ , and  $F_v$ , indicated in Tables 1615.1.2(1) and 1615.1.2(2), respectively.

**STORY DRIFT RATIO.** The story drift divided by the story height.

**TORSIONAL FORCE DISTRIBUTION.** The distribution of horizontal seismic forces through a rigid diaphragm when the center of mass of the structure at the level under consideration does not coincide with the center of rigidity (sometimes referred to as a “diaphragm rotation”).

**TOUGHNESS.** The ability of a material to absorb energy without losing significant strength.

**WIND-RESTRAINT SEISMIC SYSTEM.** The collection of structural elements that provides restraint of the seismic-isolated structure for wind loads. The wind-restraint system may be either an integral part of isolator units or a separate device.

## **SECTION 1614 EARTHQUAKE LOADS—GENERAL**

**1614.1 Scope.** Every structure, and portion thereof, shall as a minimum, be designed and constructed to resist the effects of earthquake motions and assigned a seismic design category as set forth in Section 1616.3. Structures determined to be in Seismic Design Category A need only comply with Section 1616.4.

#### **Exceptions:**

- Structures designed in accordance with the provisions of Sections 9.1 through 9.6, 9.13 and 9.14 of ASCE 7 shall be permitted.
- Detached one- and two-family dwellings as applicable in Section 101.2 in Seismic Design Categories A, B and C, or located where the mapped short-period spectral response acceleration,  $S_s$ , is less than 0.4 g, are exempt from the requirements of Sections 1613 through 1622.
- The seismic-force-resisting system of wood frame buildings that conform to the provisions of Section 2308 are not required to be analyzed as specified in Section 1616.1.
- Agricultural storage structures intended only for incidental human occupancy are exempt from the requirements of Sections 1613 through 1623.
- Structures located where mapped short-period spectral response acceleration,  $S_s$ , determined in accordance with Section 1615.1, is less than or equal to 0.15g and where the mapped spectral response acceleration at 1-second period,  $S_1$ , determined in accordance with Section 1615.1, is less than or equal to 0.04g shall be categorized as Seismic Design Category A. Seismic Design Category A structures need only comply with Section 1616.4.
- Structures located where the short-period design spectral response acceleration,  $S_{DS}$ , determined in ac-



cordance with Section 1615.1, is less than or equal to 0.167g and the design spectral response acceleration at 1-second period,  $S_{D1}$ , determined in accordance with Section 1615.1, is less than or equal to 0.067g, shall be categorized as Seismic Design Category A and need only comply with Section 1616.4.

**[EB] 1614.1.1 Additions to existing buildings.** An addition that is structurally independent from an existing structure shall be designed and constructed as required for a new structure in accordance with the seismic requirements for new structures. An addition that is not structurally independent from an existing structure shall be designed and constructed such that the entire structure conforms to the seismic-force resistance requirements for new structures unless the following conditions are satisfied:

1. The addition conforms with the requirements for new structures,
2. The addition does not increase the seismic forces in any structural element of the existing structure by more than 5 percent, unless the element has the capacity to resist the increased forces determined in accordance with Sections 1613 through 1622, and
3. Additions do not decrease the seismic resistance of any structural element of the existing structure by more than 5 percent cumulative since the original construction, unless the element has the capacity to resist the forces determined in accordance with Sections 1613 through 1622.

**[EB] 1614.2 Change of occupancy.** When a change of occupancy results in a structure being reclassified to a higher seismic use group, the structure shall conform to the seismic requirements for a new structure.

**Exceptions:**

1. Specific detailing provisions required for a new structure are not required to be met where it can be shown an equivalent level of performance and seismic safety contemplated for a new structure is obtained. Such analysis shall consider the regularity, overstrength, redundancy and ductility of the structure within the context of the specific detailing provided.
2. When a change of use results in a structure being reclassified from Seismic Use Group I to Seismic Use Group II and the structure is located in a seismic map area where  $S_{DS} < 0.33$ , compliance with this section is not required.

**[EB] 1614.3 Alterations.** Alterations are permitted to be made to any structure without requiring the structure to comply with Sections 1613 through 1623 provided the following conditions are met:

1. The alterations do not create a structural irregularity as defined in Section 1616.5 or make an existing structural irregularity more severe;
2. Alterations that increase the seismic force in any existing structural element by more than 5 percent or decrease the

design strength of any existing structural element to resist seismic forces by more than 5 percent shall not be permitted unless the entire seismic-force-resisting system is determined to conform to Sections 1613 through 1623 for a new structure; and

3. The alterations do not result in the creation of an unsafe condition.

**1614.4 Quality assurance.** A quality assurance plan shall be provided where required by Chapter 17.

**1614.5 Seismic and wind.** When the code-prescribed wind design produces greater effects, the wind design shall govern, but detailing requirements and limitations prescribed in this and referenced sections shall be followed.

**SECTION 1615  
EARTHQUAKE LOADS—SITE GROUND MOTION**

**1615.1 General procedure for determining maximum considered earthquake and design spectral response accelerations.** Ground motion accelerations, represented by response spectra and coefficients derived from these spectra, shall be determined in accordance with the general procedure of Section 1615.1, or the site-specific procedure of Section 1615.2. The site-specific procedure of Section 1615.2 shall be used for structures on sites classified as Site Class F, in accordance with Section 1615.1.1.

The mapped maximum considered earthquake spectral response acceleration at short periods ( $S_s$ ) and at 1-second period ( $S_1$ ) shall be determined from Figures 1615(1) through (10). Where a site is between contours, straight-line interpolation or the value of the higher contour shall be used.

The site class shall be determined in accordance with Section 1615.1.1. The maximum considered earthquake spectral response accelerations at short period and 1-second period adjusted for site class effects,  $S_{MS}$  and  $S_{M1}$ , shall be determined in accordance with Section 1615.1.2. The design spectral response accelerations at short period,  $S_{DS}$ , and at 1-second period,  $S_{D1}$ , shall be determined in accordance with Section 1615.1.3. The general response spectrum shall be determined in accordance with Section 1615.1.4.

**1615.1.1 Site class definitions.** The site shall be classified as one of the site classes defined in Table 1615.1.1. Where the soil shear wave velocity,  $\bar{v}_s$ , is not known, site class shall be determined, as permitted in Table 1615.1.1, from standard penetration resistance,  $\bar{N}$ , or from soil undrained shear strength,  $\bar{s}_u$ , calculated in accordance with Section 1615.1.5. Where site-specific data are not available to a depth of 100 feet (30 480 mm), appropriate soil properties are permitted to be estimated by the registered design professional preparing the soils report based on known geologic conditions.

When the soil properties are not known in sufficient detail to determine the site class, Site Class D shall be used unless the building official determines that Site Class E or F soil is likely to be present at the site.



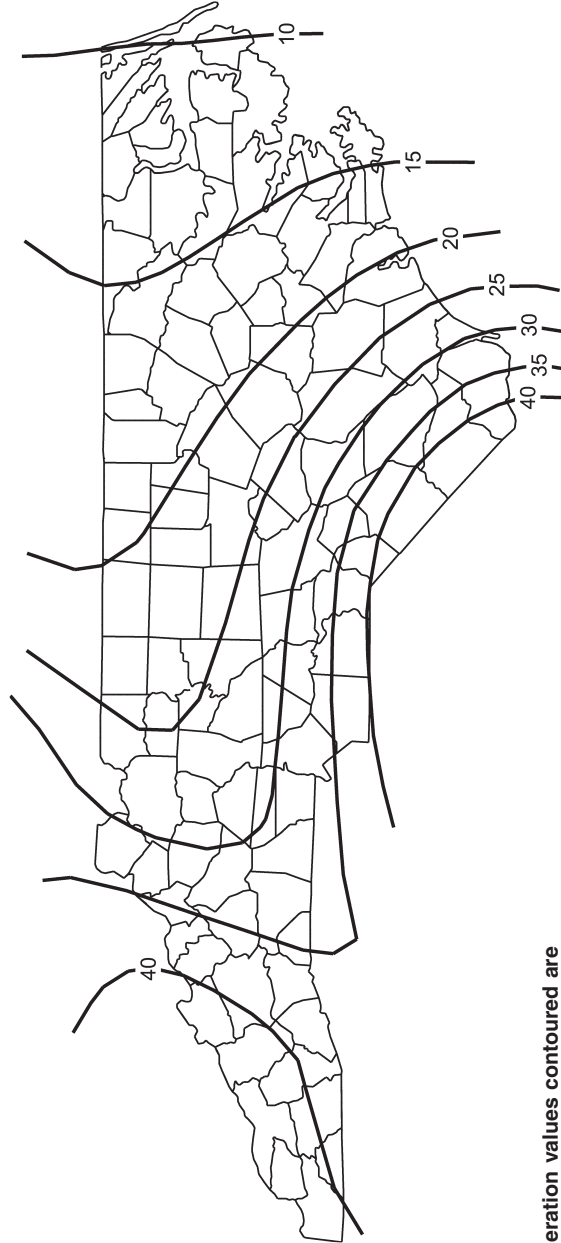

The acceleration values contoured are the random horizontal component. For design purposes, the reference design condition for the map is to be taken as NEHRP, site class B.

Note: from a map prepared by the U.S. Geological Survey.

FIGURE 1615(1)  
 MAXIMUM CONSIDERED EARTHQUAKE GROUND MOTION FOR NORTH CAROLINA  
 OF 0.2 SEC SPECTRAL RESPONSE ACCELERATION (5 PERCENT OF CRITICAL DAMPING), SITE CLASS B

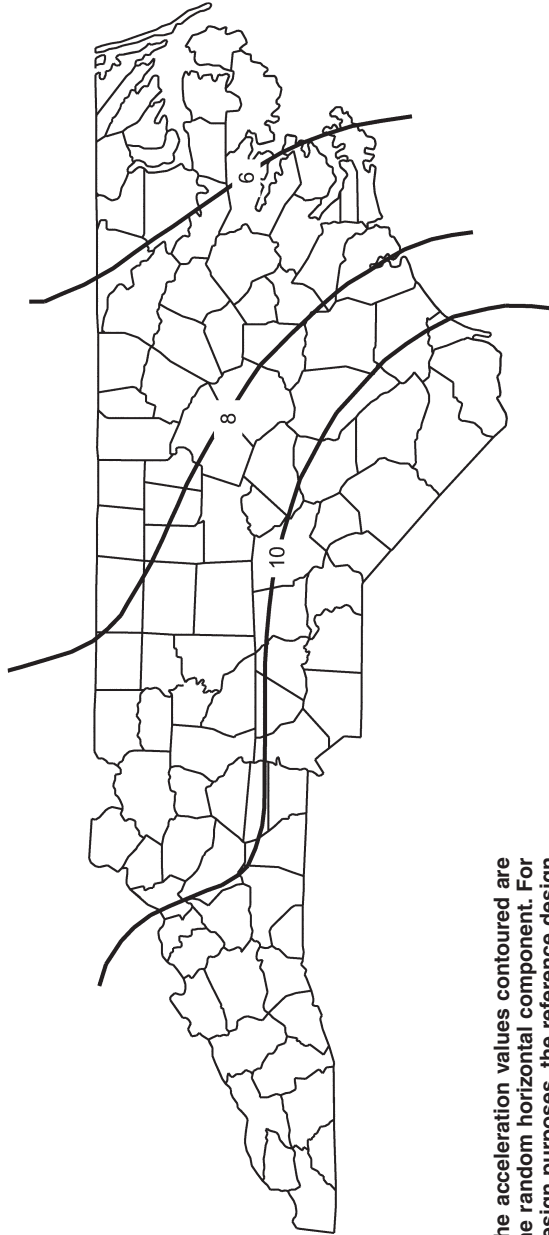

The acceleration values contoured are the random horizontal component. For design purposes, the reference design condition for the map is to be taken as NEHRP, site class B.

Note: from a map prepared by the U.S. Geological Survey.

FIGURE 1615(2)  
MAXIMUM CONSIDERED EARTHQUAKE GROUND MOTION FOR NORTH CAROLINA  
OF 1.0 SEC SPECTRAL RESPONSE ACCELERATION (5 PERCENT OF CRITICAL DAMPING), SITE CLASS B

FIGURE 1615(3)  
MAXIMUM CONSIDERED EARTHQUAKE GROUND MOTION FOR REGION 1 OF 0.2 SEC SPECTRAL  
RESPONSE ACCELERATION (5 PERCENT OF CRITICAL DAMPING), SITE CLASS B

Deleted.

FIGURE 1615(4)  
MAXIMUM CONSIDERED EARTHQUAKE GROUND MOTION FOR REGION 1 OF 1.0 SEC SPECTRAL  
RESPONSE ACCELERATION (5 PERCENT OF CRITICAL DAMPING), SITE CLASS B

Deleted.

FIGURE 1615(5)  
MAXIMUM CONSIDERED EARTHQUAKE GROUND MOTION FOR REGION 2 OF 0.2 SEC SPECTRAL  
RESPONSE ACCELERATION (5 PERCENT OF CRITICAL DAMPING), SITE CLASS B

Deleted.

FIGURE 1615(6)  
MAXIMUM CONSIDERED EARTHQUAKE GROUND MOTION FOR REGION 2 OF 1.0 SEC SPECTRAL  
RESPONSE ACCELERATION (5 PERCENT OF CRITICAL DAMPING), SITE CLASS B

Deleted.

FIGURE 1615(7)  
MAXIMUM CONSIDERED EARTHQUAKE GROUND MOTION FOR ALASKA OF 0.2 SEC SPECTRAL  
RESPONSE ACCELERATION (5 PERCENT OF CRITICAL DAMPING), SITE CLASS B

Deleted.

FIGURE 1615(8)  
MAXIMUM CONSIDERED EARTHQUAKE GROUND MOTION FOR HAWAII OF 0.2 SEC SPECTRAL  
RESPONSE ACCELERATION (5 PERCENT OF CRITICAL DAMPING), SITE CLASS B

Deleted.

FIGURE 1615(9)  
MAXIMUM CONSIDERED EARTHQUAKE GROUND MOTION FOR PUERTO RICO, CULEBRA,  
VIEQUES, ST. THOMAS, ST. JOHN, AND ST. CROIX OF 0.2 AND 1.0 SEC SPECTRAL  
RESPONSE ACCELERATION (5 PERCENT OF CRITICAL DAMPING), SITE CLASS B

Deleted.

FIGURE 1615(10)  
MAXIMUM CONSIDERED EARTHQUAKE GROUND MOTION FOR GUAM AND TUTUILLA  
OF 0.2 AND 1.0 SEC SPECTRAL RESPONSE ACCELERATION (5 PERCENT OF CRITICAL DAMPING), SITE CLASS B

Deleted.

TABLE 1615.1.1  
SITE CLASS DEFINITIONS

SITE CLASS	SOIL PROFILE NAME	AVERAGE PROPERTIES IN TOP 100 feet, AS PER SECTION 1615.1.5		
		Soil shear wave velocity, $\bar{v}_s$ , (ft/s)	Standard penetration resistance, $\bar{N}$	Soil undrained shear strength, $\bar{s}_u$ , (psf)
A	Hard rock	$\bar{v}_s > 5,000$	N/A	N/A
B	Rock	$2,500 < \bar{v}_s \leq 5,000$	N/A	N/A
C	Very dense soil and soft rock	$1,200 < \bar{v}_s \leq 2,500$	$\bar{N} > 50$	$\bar{s}_u \geq 2,000$
D	Stiff soil profile	$600 \leq \bar{v}_s \leq 1,200$	$15 \leq \bar{N} \leq 50$	$1,000 \leq \bar{s}_u \leq 2,000$
E	Soft soil profile	$\bar{v}_s < 600$	$\bar{N} < 15$	$\bar{s}_u < 1,000$
E	—	Any profile with more than 10 feet of soil having the following characteristics: 1. Plasticity index $PI > 20$ , 2. Moisture content $w \geq 40\%$ , and 3. Undrained shear strength $\bar{s}_u < 500$ psf		
F	—	Any profile containing soils having one or more of the following characteristics: 1. Soils vulnerable to potential failure or collapse under seismic loading such as liquefiable soils, quick and highly sensitive clays, collapsible weakly cemented soils. 2. Peats and/or highly organic clays ( $H > 10$ feet of peat and/or highly organic clay where $H$ = thickness of soil) 3. Very high plasticity clays ( $H > 25$ feet with plasticity index $PI > 75$ ) 4. Very thick soft/medium stiff clays ( $H > 120$ feet)		

For SI: 1 foot = 304.8 mm, 1 square foot = 0.0929 m<sup>2</sup>, 1 pound per square foot = 0.0479 kPa. N/A = Not applicable

**1615.1.2 Site coefficients and adjusted maximum considered earthquake spectral response acceleration parameters.** The maximum considered earthquake spectral response acceleration for short periods,  $S_{MS}$ , and at 1-second period,  $S_{MI}$ , adjusted for site class effects, shall be determined by Equations 16-38 and 16-39, respectively:

$$S_{MS} = F_a S_s \quad \text{(Equation 16-38)}$$

$$S_{MI} = F_v S_I \quad \text{(Equation 16-39)}$$

where:

$F_a$  = Site coefficient defined in Table 1615.1.2(1).

$F_v$  = Site coefficient defined in Table 1615.1.2(2).

$S_s$  = The mapped spectral accelerations for short periods as determined in Section 1615.1.

$S_I$  = The mapped spectral accelerations for a 1-second period as determined in Section 1615.1.

**1615.1.3 Design spectral response acceleration parameters.** Five-percent damped design spectral response acceleration at short periods,  $S_{DS}$ , and at 1-second period,  $S_{DI}$ , shall be determined from Equations 16-40 and 16-41, respectively:

$$S_{DS} = \frac{2}{3} S_{MS} \quad \text{(Equation 16-40)}$$

$$S_{DI} = \frac{2}{3} S_{MI} \quad \text{(Equation 16-41)}$$

where:

$S_{MS}$  = The maximum considered earthquake spectral response accelerations for short period as determined in Section 1615.1.2.

$S_{MI}$  = The maximum considered earthquake spectral response accelerations for 1-second period as determined in Section 1615.1.2.

**1615.1.4 General procedure response spectrum.** The general design response spectrum curve shall be developed as indicated in Figure 1615.1.4 and as follows:

1. For periods less than or equal to  $T_0$ , the design spectral response acceleration,  $S_a$ , shall be determined by Equation 16-42.
2. For periods greater than or equal to  $T_0$  and less than or equal to  $T_s$ , the design spectral response acceleration,  $S_a$ , shall be taken equal to  $S_{DS}$ .

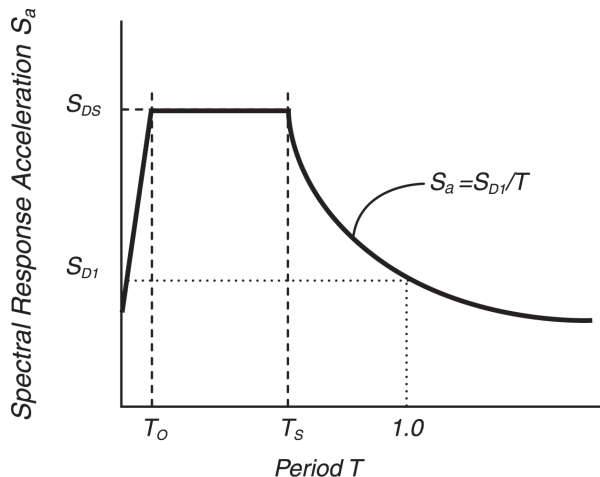

FIGURE 1615.1.4  
DESIGN RESPONSE SPECTRUM



**TABLE 1615.1.2(1)**  
**VALUES OF SITE COEFFICIENT  $F_a$  AS A FUNCTION OF SITE CLASS**  
**AND MAPPED SPECTRAL RESPONSE ACCELERATION AT SHORT PERIODS ( $S_s$ )<sup>a</sup>**

SITE CLASS	MAPPED SPECTRAL RESPONSE ACCELERATION AT SHORT PERIODS				
	$S_s \leq 0.25$	$S_s = 0.50$	$S_s = 0.75$	$S_s = 1.00$	$S_s \geq 1.25$
A	0.8	0.8	0.8	0.8	0.8
B	1.0	1.0	1.0	1.0	1.0
C	1.2	1.2	1.1	1.0	1.0
D	1.6	1.4	1.2	1.1	1.0
E	2.5	1.7	1.2	0.9	0.9
F	Note b	Note b	Note b	Note b	Note b

- a. Use straight-line interpolation for intermediate values of mapped spectral response acceleration at short period,  $S_s$ .
- b. Site-specific geotechnical investigation and dynamic site response analyses shall be performed to determine appropriate values, except that for structures with periods of vibration equal to or less than 0.5 second, values of  $F_a$  for liquefiable soils are permitted to be taken equal to the values for the site class determined without regard to liquefaction in Section 1615.1.5.1.

**TABLE 1615.1.2(2)**  
**VALUES OF SITE COEFFICIENT  $F_v$  AS A FUNCTION OF SITE CLASS**  
**AND MAPPED SPECTRAL RESPONSE ACCELERATION AT 1-SECOND PERIOD ( $S_1$ )<sup>a</sup>**

SITE CLASS	MAPPED SPECTRAL RESPONSE ACCELERATION AT 1-SECOND PERIOD				
	$S_1 \leq 0.1$	$S_1 = 0.2$	$S_1 = 0.3$	$S_1 = 0.4$	$S_1 \geq 0.5$
A	0.8	0.8	0.8	0.8	0.8
B	1.0	1.0	1.0	1.0	1.0
C	1.7	1.6	1.5	1.4	1.3
D	2.4	2.0	1.8	1.6	1.5
E	3.5	3.2	2.8	2.4	2.4
F	Note b	Note b	Note b	Note b	Note b

- a. Use straight-line interpolation for intermediate values of mapped spectral response acceleration at 1-second period,  $S_1$ .
- b. Site-specific geotechnical investigation and dynamic site response analyses shall be performed to determine appropriate values, except that for structures with periods of vibration equal to or less than 0.5 second, values of  $F_v$  for liquefiable soils are permitted to be taken equal to the values for the site class determined without regard to liquefaction in Section 1615.1.5.1.

3. For periods greater than  $T_s$ , the design spectral response acceleration,  $S_a$ , shall be determined by Equation 16-43.

$$S_a = 0.6 \frac{S_{DS}}{T_O} T + 0.4 S_{DS} \quad \text{(Equation 16-42)}$$

$$S_a = \frac{S_{DI}}{T} \quad \text{(Equation 16-43)}$$

where:

$S_{DS}$  = The design spectral response acceleration at short periods as determined in Section 1615.1.3.

$S_{DI}$  = The design spectral response acceleration at 1-second period as determined in Section 1615.1.3.

$T$  = Fundamental period (in seconds) of the structure (see Section 9.5.5.3 of ASCE 7).

$$T_O = 0.2 S_{DI} / S_{DS}$$

$$T_s = S_{DI} / S_{DS}$$

**1615.1.5 Site classification for seismic design.** Site classification for Site Class C, D or E shall be determined from Table 1615.1.5.

The notations presented below apply to the upper 100 feet (30 480 mm) of the site profile. Profiles containing distinctly different soil layers shall be subdivided into those layers designated by a number that ranges from 1 to  $n$  at the bottom where there is a total of  $n$  distinct layers in the upper 100 feet (30 480 mm). The symbol,  $i$ , then refers to any one of the layers between 1 and  $n$ .

where:

$v_{si}$  = The shear wave velocity in feet per second (m/s).

$d_i$  = The thickness of any layer between 0 and 100 feet (30 480 mm).

$$\bar{v}_s = \frac{\sum_{i=1}^n d_i}{\sum_{i=1}^n \frac{d_i}{v_{si}}} \quad \text{(Equation 16-44)}$$

$$\sum_{i=1}^n d_i = 100 \text{ feet (30 480 mm)}$$

$N_i$  is the Standard Penetration Resistance (ASTM D 1586) not to exceed 100 blows/foot (mm) as directly measured in the field without corrections.

$$\bar{N} = \frac{\sum_{i=1}^n d_i}{\sum_{i=1}^n \frac{d_i}{N_i}} \quad \text{(Equation 16-45)}$$

$$\bar{N}_{ch} = \frac{d_s}{\sum_{i=1}^m \frac{d_i}{N_i}} \quad \text{(Equation 16-46)}$$

where:

$$\sum_{i=1}^m d_i = d_s$$

Use only  $d_i$  and  $N_i$  for cohesionless soils.

$d_s$  = The total thickness of cohesionless soil layers in the top 100 feet (30 480 mm).

$s_{ui}$  = The undrained shear strength in psf (kPa), not to exceed 5,000 psf (240 kPa), ASTM D 2166 or D 2850.

$$\bar{s}_u = \frac{d_c}{\sum_{i=1}^k \frac{d_i}{s_{ui}}} \quad \text{(Equation 16-47)}$$

where:

$$\sum_{i=1}^k d_i = d_c$$

$d_c$  = The total thickness (100 –  $d_s$ ) (For SI: 30 480 –  $d_s$ ) of cohesive soil layers in the top 100 feet (30 480 mm).

$PI$  = The plasticity index, ASTM D 4318.

$w$  = The moisture content in percent, ASTM D 2216.

The shear wave velocity for rock, Site Class B, shall be either measured on site or estimated by a geotechnical engineer or engineering geologist/seismologist for competent rock with moderate fracturing and weathering. Softer and more highly fractured and weathered rock shall either be measured on site for shear wave velocity or classified as Site Class C.

The hard rock, Site Class A, category shall be supported by shear wave velocity measurements either on site or on profiles of the same rock type in the same formation with an

equal or greater degree of weathering and fracturing. Where hard rock conditions are known to be continuous to a depth of 100 feet (30 480 mm), surficial shear wave velocity measurements are permitted to be extrapolated to assess  $\bar{v}_s$ .

The rock categories, Site Classes A and B, shall not be used if there is more than 10 feet (3048 mm) of soil between the rock surface and the bottom of the spread footing or mat foundation.

**1615.1.5.1 Steps for classifying a site.**

1. Check for the four categories of Site Class F requiring site-specific evaluation. If the site corresponds to any of these categories, classify the site as Site Class F and conduct a site-specific evaluation.
2. Check for the existence of a total thickness of soft clay > 10 feet (3048 mm) where a soft clay layer is defined by:  $\bar{s}_u < 500$  psf (25 kPa),  $w \geq 40$  percent, and  $PI > 20$ . If these criteria are satisfied, classify the site as Site Class E.
3. Categorize the site using one of the following three methods with  $\bar{v}_s$ ,  $\bar{N}$ , and  $\bar{s}_u$  computed in all cases as specified.
  - 3.1.  $\bar{v}_s$  for the top 100 feet (30 480 mm) ( $\bar{v}_s$  method).
  - 3.2.  $\bar{N}$  for the top 100 feet (30 480 mm) ( $\bar{N}$  method).
  - 3.3.  $\bar{N}_{ch}$  for cohesionless soil layers ( $PI < 20$ ) in the top 100 feet (30 480 mm) and average,  $\bar{s}_u$ , for cohesive soil layers ( $PI > 20$ ) in the top 100 feet (30 480 mm) ( $\bar{s}_u$  method).

**1615.2 Site-specific procedure for determining ground motion accelerations.** A site-specific study shall account for the regional seismicity and geology; the expected recurrence rates and maximum magnitudes of events on known faults and source zones; the location of the site with respect to these; near source effects if any and the characteristics of subsurface site conditions.

**1615.2.1 Probabilistic maximum considered earthquake.** Where site-specific procedures are used as required or permitted by Section 1615, the maximum considered earthquake ground motion shall be taken as that motion represented by an acceleration response spectrum having a 2-percent probability of exceedance within a 50-year period. The maximum considered earthquake spectral re-

**TABLE 1615.1.5  
SITE CLASSIFICATION<sup>a</sup>**

SITE CLASS	$\bar{v}_s$	$\bar{N}$ or $\bar{N}_{ch}$	$\bar{s}_u$
E	< 600 ft/s	< 15	< 1,000 psf
D	600 to 1,200 ft/s	15 to 50	1,000 to 2,000 psf
C	1,200 to 2,500 ft/s	> 50	> 2,000

For SI: 1 foot per second = 304.8 mm per second, 1 pound per square foot = 0.0479kN/m<sup>2</sup>.

a. If the  $\bar{s}_u$  method is used and the  $\bar{N}_{ch}$  and  $\bar{s}_u$  criteria differ, select the category with the softer soils (for example, use Site Class E instead of D).

sponse acceleration at any period,  $S_{aM}$ , shall be taken from the 2-percent probability of exceedance within a 50-year period spectrum.

**Exception:** Where the spectral response ordinates at 0.2 second or 1 second for a 5-percent damped spectrum having a 2-percent probability of exceedance within a 50-year period exceed the corresponding ordinates of the deterministic limit of Section 1615.2.2, the maximum considered earthquake ground motion spectrum shall be taken as the lesser of the probabilistic maximum considered earthquake ground motion or the deterministic maximum considered earthquake ground motion spectrum of Section 1615.2.3, but shall not be taken as less than the deterministic limit ground motion of Section 1615.2.2.

**1615.2.2 Deterministic limit on maximum considered earthquake ground motion.** The deterministic limit for the maximum considered earthquake ground motion shall be the response spectrum determined in accordance with Figure 1615.2.2, where site coefficients,  $F_a$  and  $F_v$ , are determined in accordance with Section 1615.1.2, with the value of the mapped short-period spectral response acceleration,  $S_s$ , taken as 1.5g and the value of the mapped spectral response acceleration at 1 second,  $S_1$ , taken as 0.6g.

**1615.2.3 Deterministic maximum considered earthquake ground motion.** The deterministic maximum considered earthquake ground motion response spectrum shall be calculated as 150 percent of the median spectral response accelerations,  $S_{aM}$ , at all periods resulting from a characteristic earthquake on any known active fault within the region.

**1615.2.4 Site-specific design ground motion.** Where site-specific procedures are used to determine the maximum considered earthquake ground motion response spectrum, the design spectral response acceleration,  $S_a$ , at any period shall be determined from Equation 16-48:

$$S_a = \frac{2}{3} S_{aM} \tag{Equation 16-48}$$

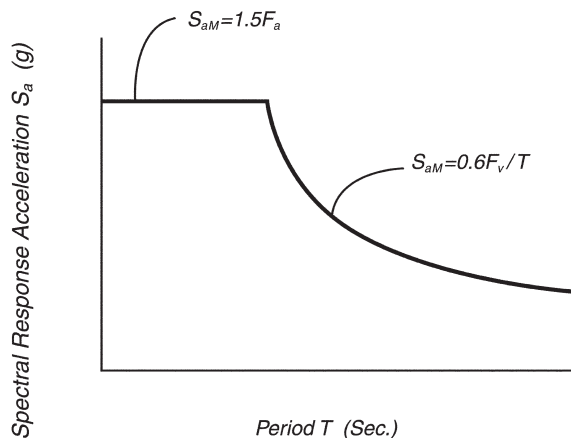

**FIGURE 1615.2.2**  
**DETERMINISTIC LIMIT ON MAXIMUM CONSIDERED**  
**EARTHQUAKE RESPONSE SPECTRUM**

and shall be greater than or equal to 80 percent of the design spectral response acceleration,  $S_a$ , determined by the general response spectrum in Section 1615.1.4.

**1615.2.5 Design spectral response coefficients.** Where the site-specific procedure is used to determine the design ground motion in accordance with Section 1615.2.4, the parameter  $S_{DS}$  shall be taken as the spectral acceleration,  $S_a$ , obtained from the site-specific spectra at a period of 0.2 second, except that it shall not be taken as less than 90 percent of the peak spectral acceleration,  $S_a$ , at any period. The parameter  $S_{D1}$  shall be taken as the greater of the spectral acceleration,  $S_a$ , at a period of 1 second or two times the spectral acceleration,  $S_a$ , at a period of 2 seconds. The parameters  $S_{MS}$  and  $S_{M1}$  shall be taken as 1.5 times  $S_{DS}$  and  $S_{D1}$ , respectively. The values so obtained shall not be taken as less than 80 percent of the values obtained from the general procedures of Section 1615.1.

**SECTION 1616**  
**EARTHQUAKE LOADS—CRITERIA SELECTION**

**1616.1 Structural design criteria.** Each structure shall be assigned to a seismic design category in accordance with Section 1616.3. Seismic design categories are used in this code to determine permissible structural systems, limitations on height and irregularity, those components of the structure that must be designed for seismic resistance and the types of lateral force analysis that must be performed. Each structure shall be provided with complete lateral- and vertical-force-resisting systems capable of providing adequate strength, stiffness and energy dissipation capacity to withstand the design earthquake ground motions determined in accordance with Section 1615 within the prescribed deformation limits of Section 1617.3. The design ground motions shall be assumed to occur along any horizontal direction of a structure. A continuous load path, or paths, with adequate strength and stiffness to transfer forces induced by the design earthquake ground motions from the points of application to the final point of resistance shall be provided.

Allowable stress design is permitted to be used to evaluate sliding, overturning and soil bearing at the soil-structure interface regardless of the approach used in the design of the structure, provided load combinations of Section 1605.3 are utilized. When using allowable stress design for proportioning foundations, the value of  $0.2 S_{DS}D$  in Equations 16-50, 16-51, 16-52 and 16-53 or Equations 9.5.2.7-1, 9.5.2.7-2, 9.5.2.7.1-1 and 9.5.2.7.1-2 of ASCE 7 is permitted to be taken equal to zero. When the load combinations of Section 1605.3.2 are utilized, a one-third increase in soil allowable stresses is permitted for all load combinations that include  $W$  or  $E$ .

**1616.2 Seismic use groups and occupancy importance factors.** Each structure shall be assigned a seismic use group and a corresponding occupancy importance factor ( $I_E$ ) as indicated in Table 1604.5.

**1616.2.1 Seismic Use Group I.** Seismic Use Group I structures are those not assigned to either Seismic Use Group II or III.

**1616.2.2 Seismic Use Group II.** Seismic Use Group II structures are those, the failure of which would result in a substantial public hazard due to occupancy or use as indicated by Table 1604.5, or as designated by the building official.

**1616.2.3 Seismic Use Group III.** Seismic Use Group III structures are those having essential facilities that are required for postearthquake recovery and those containing substantial quantities of hazardous substances, as indicated in Table 1604.5, or as designated by the building official.

Where operational access to a Seismic Use Group III structure is required through an adjacent structure, the adjacent structure shall conform to the requirements for Seismic Use Group III structures. Where operational access is less than 10 feet (3048 mm) from an interior lot line or less than 10 feet (3048 mm) from another structure, access protection from potential falling debris shall be provided by the owner of the Seismic Use Group III structure.

**1616.2.4 Multiple occupancies.** Where a structure is occupied for two or more occupancies not included in the same seismic use group, the structure shall be assigned the classification of the highest seismic use group corresponding to the various occupancies.

Where structures have two or more portions that are structurally separated in accordance with Section 1620, each portion shall be separately classified. Where a structurally separated portion of a structure provides required access to, required egress from or shares life safety components with another portion having a higher seismic use group, both portions shall be assigned the higher seismic use group.

**1616.3 Determination of seismic design category.** All structures shall be assigned to a seismic design category based on their seismic use group and the design spectral response acceleration coefficients,  $S_{DS}$  and  $S_{DI}$ , determined in accordance with Section 1615.1.3 or 1615.2.5. Each building and structure shall be assigned to the most severe seismic design category in accordance with Table 1616.3(1) or 1616.3(2), irrespective of the fundamental period of vibration of the structure,  $T$ .

**Exception:** The seismic design category is permitted to be determined from Table 1616.3(1) alone when all of the following apply:

1. The approximate fundamental period of the structure,  $T_a$ , in each of the two orthogonal directions determined in accordance with Section 9.5.5.3.2 of ASCE 7, is less than  $0.8 T_s$  determined in accordance with Section 1615.1.4,
2. Equation 9.5.5.2.1-1 of ASCE 7 is used to determine the seismic response coefficient,  $C_s$ , and
3. The diaphragms are rigid as defined in Section 1602.

**1616.3.1 Site limitation for Seismic Design Category E or F.** A structure assigned to Seismic Design Category E or F shall not be sited over an identified active fault trace.

**Exception:** Detached Group R-3 as applicable in Section 101.2 of light-frame construction.

**TABLE 1616.3(1)  
SEISMIC DESIGN CATEGORY BASED ON  
SHORT-PERIOD RESPONSE ACCELERATIONS**

VALUE OF $S_{DS}$	SEISMIC USE GROUP		
	I	II	III
$S_{DS} < 0.167g$	A	A	A
$0.167g \leq S_{DS} < 0.33g$	B	B	C
$0.33g \leq S_{DS} < 0.50g$	C	C	D
$0.50g \leq S_{DS}$	D <sup>a</sup>	D <sup>a</sup>	D <sup>a</sup>

a. Seismic Use Group I and II structures located on sites with mapped maximum considered earthquake spectral response acceleration at 1-second period,  $S_I$ , equal to or greater than  $0.75g$ , shall be assigned to Seismic Design Category E, and Seismic Use Group III structures located on such sites shall be assigned to Seismic Design Category F.

**TABLE 1616.3(2)  
SEISMIC DESIGN CATEGORY BASED ON  
1-SECOND PERIOD RESPONSE ACCELERATION**

VALUE OF $S_{DI}$	SEISMIC USE GROUP		
	I	II	III
$S_{DI} < 0.067g$	A	A	A
$0.067g \leq S_{DI} < 0.133g$	B	B	C
$0.133g \leq S_{DI} < 0.20g$	C	C	D
$0.20g \leq S_{DI}$	D <sup>a</sup>	D <sup>a</sup>	D <sup>a</sup>

a. Seismic Use Group I and II structures located on sites with mapped maximum considered earthquake spectral response acceleration at 1-second period,  $S_I$ , equal to or greater than  $0.75g$ , shall be assigned to Seismic Design Category E, and Seismic Use Group III structures located on such sites shall be assigned to Seismic Design Category F.

**1616.4 Design requirements for Seismic Design Category**

**A.** Structures assigned to Seismic Design Category A need only comply with the requirements of Sections 1616.4.1 through 1616.4.5.

**1616.4.1 Minimum lateral force.** Structures shall be provided with a complete lateral-force-resisting system designed to resist the minimum lateral force,  $F_x$ , applied simultaneously at each floor level given by Equation 16-49:

$$F_x = 0.01 w_x \tag{Equation 16-49}$$

where:

$F_x$  = The design lateral force applied at Level  $x$ .

$w_x$  = The portion of the total gravity load of the structure,  $W$ , located or assigned to Level  $x$ .

$W$  = The total dead load and other loads listed below:

1. In areas used for storage, a minimum of 25 percent of the reduced floor live load (floor live load in public garages and open parking structures need not be included).
2. Where an allowance for partition load is included in the floor load design, the actual partition weight or a minimum weight of 10 psf ( $0.479 \text{ kN/m}^2$ ) of floor area, whichever is greater.
3. Total operating weight of permanent equipment.



4. Twenty percent of flat roof snow load where flat roof snow load exceeds 30 psf (1.44 kN/m<sup>2</sup>).

The direction of application of seismic forces used in design shall be that which will produce the most critical load effect in each component. The design seismic forces are permitted to be applied separately in each of two orthogonal directions and orthogonal effects are permitted to be neglected.

The effect of this lateral force shall be taken as  $E$  in the load combinations prescribed in Section 1605.2 for strength or load and resistance factor design methods, or Section 1605.3 for allowable stress design methods. Special seismic load combinations that include  $E_m$  need not be considered.

**1616.4.2 Connections.** All parts of the structure between separation joints shall be interconnected, and the connections shall be capable of transmitting the seismic force,  $F_p$ , induced in the connection by the parts being connected. Any smaller portion of the structure shall be tied to the remainder of the structure for  $F_p$  equal to 0.05 times the weight of the smaller portion. A positive connection for resisting horizontal forces acting on the member shall be provided for each beam, girder or truss to its support. The connection shall have strength sufficient to resist 5 percent of the dead and live load vertical reaction applied horizontally.

**1616.4.3 Anchorage of concrete or masonry walls.** See Section 1604.8.2.

**1616.4.4 Conventional light-frame construction.** Buildings constructed in compliance with Section 2308 are deemed to comply with Sections 1616.4.1, 1616.4.2 and 1616.4.3.

**1616.4.5 Tank freeboard.** Tanks in Seismic Use Group III according to Table 9.14.5.1.2 of ASCE 7 shall also comply with the freeboard requirements of Section 9.14.7.3.6.1.2 of ASCE 7.

**1616.5 Building configuration.** Buildings shall be classified as regular or irregular based on the criteria in Section 9.5.2.3 of ASCE 7.

**Exception:** Buildings designed using the simplified analysis procedure in Section 1617.5 shall be classified in accordance with Section 1616.5.1.

**1616.5.1 Building configuration (for use in the simplified analysis procedure of Section 1617.5).** Buildings designed using the simplified analysis procedure in Section 1617.5 shall be classified as regular or irregular based on the criteria in this section. Such classification shall be based on the plan and vertical configuration. Buildings shall not exceed the limitations of Section 1616.6.1.

**1616.5.1.1 Plan irregularity.** Buildings having one or more of the features listed in Table 1616.5.1.1 shall be designated as having plan structural irregularity and shall comply with the requirements in the sections referenced in that table.

**1616.5.1.2 Vertical irregularity.** Buildings having one or more of the features listed in Table 1616.5.1.2 shall be designated as having vertical irregularity and shall comply with the requirements in the sections referenced in that table.

**Exceptions:**

1. Structural irregularities of Type 1a, 1b or 2 in Table 1616.5.1.2 do not apply where no story drift ratio under design lateral load is greater than 130 percent of the story drift ratio of the next story above. Torsional effects need not be considered in the calculation of story drifts for the purpose of this determination. The story drift ratio relationship for the top two stories of the building is not required to be evaluated.
2. Irregularities of Types 1a, 1b and 2 of Table 1616.5.1.2 are not required to be considered for one-story buildings in any seismic design category or for two-story buildings in Seismic Design Category A, B, C or D.

**1616.6 Analysis procedures.** A structural analysis conforming to one of the types permitted in Section 9.5.2.5.1 of ASCE 7 or to the simplified procedure in Section 1617.5 shall be made for all structures. The analysis shall form the basis for determining the seismic forces,  $E$  and  $E_m$ , to be applied in the load combinations of Section 1605 and shall form the basis for determining the design drift as required by Section 9.5.2.8 of ASCE 7 or Section 1617.3.

**Exceptions:**

1. Structures assigned to Seismic Design Category A.
2. Design drift need not be evaluated in accordance with Section 1617.3 when the simplified analysis method of Section 1617.5 is used.

**1616.6.1 Simplified analysis.** A simplified analysis, in accordance with Section 1617.5, shall be permitted to be used for any structure in Seismic Use Group I, subject to the following limitations, or a more rigorous analysis shall be made:

1. Buildings of light-framed construction not exceeding three stories in height, excluding basements.
2. Buildings of any construction other than light-framed construction, not exceeding two stories in height, excluding basements, with flexible diaphragms at every level as defined in Section 1602.

**1616.6.2 Alternative structural design criteria for simple bearing wall or building frame systems.** Simple bearing wall and building frame systems and their components meeting the qualifications of the 2003 NEHRP Recommended Provisions for Seismic Regulations for New Buildings and Other Structures (FEMA 450), Alternative Simplified Chapter 4, shall be permitted to be designed as an alternate to Section 1616.6.



**TABLE 1616.5.1.1  
PLAN STRUCTURAL IRREGULARITIES**

IRREGULARITY TYPE AND DESCRIPTION		REFERENCE SECTION	SEISMIC DESIGN CATEGORY <sup>a</sup> APPLICATION
1a	Torsional Irregularity—to be considered when diaphragms are not flexible as determined in Section 1602.1.1 Torsional irregularity shall be considered to exist when the maximum story drift, computed including accidental torsion, at one end of the structure transverse to an axis is more than 1.2 times the average of the story drifts at the two ends of the structure.	9.5.5.5.2 of ASCE 7 1620.4.1 9.5.2.5.1 of ASCE 7 9.5.5.7.1 of ASCE 7	C, D, E and F D, E and F D, E and F C, D, E and F
1b	Extreme Torsional Irregularity—to be considered when diaphragms are not flexible as determined in Section 1602.1. Extreme torsional irregularity shall be considered to exist when the maximum story drift, computed and including accidental torsion, at one end of the structure transverse to an axis is more than 1.4 times the average of the story drifts at the two ends of the structure.	9.5.5.5.2 of ASCE 7 1620.4.1 1620.5.1 9.5.2.5.1 of ASCE 7 9.5.5.7.1 of ASCE 7	C, D, E and F D E and F D, E and F C, D, E and F
2	Reentrant Corners Plan configurations of a structure and its lateral-force-resisting system contain reentrant corners where both projections of the structure beyond a reentrant corner are greater than 15 percent of the plan dimension of the structure in the given direction.	1620.4.1	D, E and F
3	Diaphragm Discontinuity Diaphragms with abrupt discontinuities or variations in stiffness, including those having cutout or open areas greater than 50 percent of the gross enclosed diaphragm area, or changes in effective diaphragm stiffness of more than 50 percent from one story to the next.	1620.4.1	D, E and F
4	Out-of-Plane Offsets Discontinuities in a lateral-force-resistance path, such as out-of-plane offsets of the vertical elements.	1620.4.1 9.5.2.5.1 of ASCE 7 1620.2.9	D, E and F D, E and F B, C, D, E and F
5	Nonparallel Systems The vertical lateral-force-resisting elements are not parallel to or symmetric about the major orthogonal axes of the lateral-force-resisting system.	1620.3.2	C, D, E and F

a. Seismic design category is determined in accordance with Section 1616.

**TABLE 1616.5.1.2  
VERTICAL STRUCTURAL IRREGULARITIES**

IRREGULARITY TYPE AND DESCRIPTION		REFERENCE SECTION	SEISMIC DESIGN CATEGORY <sup>a</sup> APPLICATION
1a	Stiffness Irregularity—Soft Story A soft story is one in which the lateral stiffness is less than 70 percent of that in the story above or less than 80 percent of the average stiffness of the three stories above.	9.5.2.5.1 of ASCE 7	D, E, and F
1b	Stiffness Irregularity—Extreme Soft Story An extreme soft story is one in which the lateral stiffness is less than 60 percent of that in the story above or less than 70 percent of the average stiffness of the three stories above.	1620.5.1 9.5.2.5.1 of ASCE 7	E and F D, E and F
2	Weight (Mass) Irregularity Mass irregularity shall be considered to exist where the effective mass of any story is more than 150 percent of the effective mass of an adjacent story. A roof that is lighter than the floor below need not be considered.	9.5.2.5.1 of ASCE 7	D, E and F
3	Vertical Geometric Irregularity Vertical geometric irregularity shall be considered to exist where the horizontal dimension of the lateral-force-resisting system in any story is more than 130 percent of that in an adjacent story.	9.5.2.5.1 of ASCE 7	D, E and F
4	In-plane Discontinuity in Vertical Lateral-Force-Resisting Elements An in-plane offset of the lateral-force-resisting elements greater than the length of those elements or a reduction in stiffness of the resisting element in the story below.	1620.4.1 9.5.2.5.1 of ASCE 7 1620.2.9	D, E and F D, E and F B, C, D, E and F
5	Discontinuity in Capacity—Weak Story A weak story is one in which the story lateral strength is less than 80 percent of that in the story above. The story strength is the total strength of seismic-resisting elements sharing the story shear for the direction under consideration.	1620.2.3 9.5.2.5.1 of ASCE 7 1620.5.1	B, C, D, E and F D, E and F E and F

a. Seismic design category is determined in accordance with Section 1616.

## SECTION 1617 EARTHQUAKE LOADS—MINIMUM DESIGN LATERAL FORCE AND RELATED EFFECTS

**1617.1 Seismic load effect  $E$  and  $E_m$ .** The seismic load effect,  $E$ , for use in the basic load combinations of Sections 1605.2 and 1605.3 shall be determined from Section 9.5.2.7 of ASCE 7. The maximum seismic load effect,  $E_m$ , for use in the special seismic load combination of Section 1605.4 shall be the special seismic load determined from Section 9.5.2.7.1 of ASCE 7.

**Exception:** For structures designed using the simplified analysis procedure in Section 1617.5, the seismic load effects,  $E$  and  $E_m$ , shall be determined from Section 1617.1.1.

**1617.1.1 Seismic load effects,  $E$  and  $E_m$  (for use in the simplified analysis procedure of Section 1617.5).** Seismic load effects,  $E$  and  $E_m$ , for use in the load combinations of Section 1605 for structures designed using the simplified analysis procedure in Section 1617.5 shall be determined as follows.

**1617.1.1.1 Seismic load effect,  $E$ .** Where the effects of gravity and the seismic ground motion are additive, seismic load,  $E$ , for use in Equations 16-5, 16-10 and 16-17, shall be defined by Equation 16-50:

$$E = \rho Q_E + 0.2 S_{DS} D \quad (\text{Equation 16-50})$$

where:

$D$  = The effect of dead load.

$E$  = The combined effect of horizontal and vertical earthquake-induced forces.

$\rho$  = A redundancy coefficient obtained in accordance with Section 1617.2.

$Q_E$  = The effect of horizontal seismic forces.

$S_{DS}$  = The design spectral response acceleration at short periods obtained from Section 1615.1.3 or 1615.2.5.

Where the effects of gravity and seismic ground motion counteract, the seismic load,  $E$ , for use in Equations 16-6, 16-12 and 16-18 shall be defined by Equation 16-51.

$$E = \rho Q_E - 0.2 S_{DS} D \quad (\text{Equation 16-51})$$

Design shall use the load combinations prescribed in Section 1605.2 for strength or load and resistance factor design methodologies, or Section 1605.3 for allowable stress design methods.

**1617.1.1.2 Maximum seismic load effect,  $E_m$ .** The maximum seismic load effect,  $E_m$ , shall be used in the special seismic load combinations in Section 1605.4.

Where the effects of the seismic ground motion and gravity loads are additive, seismic load,  $E_m$ , for use in Equation 16-19, shall be defined by Equation 16-52.

$$E_m = \Omega_0 Q_E + 0.2 S_{DS} D \quad (\text{Equation 16-52})$$

Where the effects of the seismic ground and gravity loads counteract, seismic load,  $E_m$ , for use in Equation 16-20, shall be defined by Equation 16-53.

$$E_m = \Omega_0 Q_E - 0.2 S_{DS} D \quad (\text{Equation 16-53})$$

where  $E$ ,  $Q_E$ ,  $S_{DS}$  are as defined above and  $\Omega_0$  is the system overstrength factor as given in Table 1617.6.2.

The term  $\Omega_0 Q_E$  need not exceed the maximum force that can be transferred to the element by the other elements of the lateral-force-resisting system.

Where allowable stress design methodologies are used with the special load combinations of Section 1605.4, design strengths are permitted to be determined using an allowable stress increase of 1.7 and a resistance factor,  $\phi$ , of 1.0. This increase shall not be combined with increases in allowable stresses or load combination reductions otherwise permitted by this code or the material reference standard except that combination with the duration of load increases in Chapter 23 is permitted.

**1617.2 Redundancy.** The provisions given in Section 9.5.2.4 of ASCE 7 shall be used.

**Exception:** Structures designed using the simplified analysis procedure in Section 1617.5 shall use the redundancy provisions in Sections 1617.2.2.

**1617.2.1 ASCE 7, Sections 9.5.2.4.2 and 9.5.2.4.3.** Modify Sections 9.5.2.4.2 and 9.5.2.4.3 as follows:

**9.5.2.4.2 Seismic Design Category D:** For structures in Seismic Design Category D,  $\rho$  shall be taken as the largest of the values of  $\rho_x$  calculated at each story “ $x$ ” of the structure in accordance with Equation 9.5.2.4.2-1 as follows:

$$\rho_x = 2 - \frac{20}{r_{max_x} \sqrt{A_x}}$$

where:

$r_{max_x}$  = The ratio of the design story shear resisted by the single element carrying the most shear force in the story to the total story shear, for a given direction of loading. For braced frames, the value of  $r_{max_x}$  is equal to the lateral force component in the most heavily loaded brace element divided by the story shear. For moment frames,  $r_{max_x}$  shall be taken as the maximum of the sum of the shears in any two adjacent columns in the plane of a moment frame divided by the story shear. For columns common to two bays with moment-resisting connections on opposite sides at the level under consideration, 70 percent of the shear in that column is permitted to be used in the column shear summation. For shear walls,  $r_{max_x}$  shall be taken equal to shear in the most heavily loaded wall or wall pier multiplied by  $10/l_w$  (the metric coefficient is  $3.3/l_w$ ), divided by the story shear, where  $l_w$  is the wall or wall pier length in feet (m). The value of the ratio of  $10/l_w$  need not be greater than 1.0 for buildings of light-framed construc-

tion. For dual systems,  $r_{max_x}$  shall be taken as the maximum value defined above, considering all lateral-load-resisting elements in the story. The lateral loads shall be distributed to elements based on relative rigidities considering the interaction of the dual system. For dual systems, the value of  $\rho$  need not exceed 80 percent of the value calculated above.

$A_x$  = The floor area in square feet of the diaphragm level immediately above the story.

Calculation of  $r_{max_x}$  need not consider the effects of accidental torsion and any dynamic amplification of torsion required by Section 9.5.5.5.2.

For a story with a flexible diaphragm immediately above,  $r_{max_x}$  shall be permitted to be calculated from an analysis that assumes rigid diaphragm behavior and  $\rho_x$ , need not exceed 1.25.

The value of  $\rho$  need not exceed 1.5, which is permitted to be used for any structure. The value of  $\rho$  shall not be taken as less than 1.0.

**Exception:** For structures with seismic-force-resisting systems in any direction comprised solely of special moment frames, the seismic-force-resisting system shall be configured such that the value of  $\rho$  calculated in accordance with this section does not exceed 1.25. The calculated value of  $\rho$  is permitted to exceed this limit when the design story drift,  $\Delta$ , as determined in Section 9.5.5.7, does not exceed  $\Delta_a/\rho$  for any story where  $\Delta_a$  is the allowable story drift from Table 9.5.2.8.

The metric equivalent of Equation 9.5.2.4.2-1 is:

$$\rho_x = 2 - \frac{6.1}{r_{max_x} \sqrt{A_x}}$$

where:  $A_x$  is in square meters.

The value  $\rho$  shall be permitted to be taken equal to 1.0 in the following circumstances:

1. When calculating displacements for dynamic amplification of torsion in Section 9.5.5.5.2.
2. When calculating deflections, drifts and seismic shear forces related to Sections 9.5.5.7.1 and 9.5.5.7.2.
3. For design calculations required by Section 9.5.2.6, 9.6 or 9.14.

For structures with vertical combinations of seismic-force-resisting systems, the value of  $\rho$  shall be determined independently for each seismic-force-resisting system. The redundancy coefficient of the lower portion shall not be less than the following:

$$\rho_L = \frac{R_L \rho_u}{R_u}$$

where:

$\rho_L = \rho$  of lower portion.

$R_L = R$  of lower portion.

$\rho_u = \rho$  of upper portion.

$R_u = R$  of upper portion.

9.5.2.4.3 Seismic Design Categories E and F. For structures in Seismic Design Categories E and F, the value of  $\rho$  shall be calculated as indicated in Section 9.5.2.4.2, above.

**Exception:** For structures with lateral-force-resisting systems in any direction consisting solely of special moment frames, the lateral-force-resisting system shall be configured such that the value of  $\rho$  calculated in accordance with Section 9.5.2.4.2 does not exceed 1.1. The calculated value of  $\rho$  is permitted to exceed this limit when the design story drift,  $\Delta$ , as determined in Section 9.5.5.7, does not exceed  $\Delta_a/\rho$  for any story where  $\Delta_a$  is the allowable story drift from Table 9.5.2.8.

**1617.2.2 Redundancy (for use in the simplified analysis procedure of Section 1617.5).** A redundancy coefficient,  $\rho$ , shall be assigned to each structure designed using the simplified analysis procedure in Section 1617.5 in accordance with this section. Buildings shall not exceed the limitations of Section 1616.6.1.

**1617.2.2.1 Seismic Design Category A, B or C.** For structures assigned to Seismic Design Category A, B or C (see Section 1616), the value of the redundancy coefficient  $\rho$  is 1.0.

**1617.2.2.2 Seismic Design Category D, E or F.** For structures in Seismic Design Category D, E or F (see Section 1616), the redundancy coefficient,  $\rho$ , shall be taken as the largest of the values of,  $\rho_i$ , calculated at each story “ $i$ ” of the structure in accordance with Equation 16-54, as follows:

$$\rho_i = 2 - \frac{20}{r_{max_i} \sqrt{A_i}} \quad \text{(Equation 16-54)}$$

For SI:

$$\rho_i = 2 - \frac{6.1}{r_{max_i} \sqrt{A_i}}$$

where:

$r_{max_i}$  = The ratio of the design story shear resisted by the most heavily loaded single element in the story to the total story shear, for a given direction of loading.

$r_{max_i}$  = For braced frames, the value  $r_{max_i}$ , is equal to the horizontal force component in the most heavily loaded brace element divided by the story shear.

$r_{max_i}$  = For moment frames,  $r_{max_i}$ , shall be taken as the maximum of the sum of the shears in any two adjacent columns in a moment frame divided by the story shear. For columns common to two bays with moment-resisting connections on opposite sides at the level under consideration, it is permitted to use 70 percent of the shear in that column in the column shear summation.

$r_{max_i}$  = For shear walls,  $r_{max_i}$ , shall be taken as the maximum value of the product of the shear in the wall or wall pier and  $10/l_w$  (3.3/ $l_w$  for SI), divided by the story shear, where  $l_w$  is the length of the wall or wall pier in feet (m). In light-framed construction, the value of the ratio of  $10/l_w$  need not be greater than 1.0.

$r_{max_i}$  = For dual systems,  $r_{max_i}$ , shall be taken as the maximum value defined above, considering all lateral-load-resisting elements in the story. The lateral loads shall be distributed to elements based on relative rigidities considering the interaction of the dual system. For dual systems, the value of  $\rho$  need not exceed 80 percent of the value calculated above.

$A_i$  = The floor area in square feet of the diaphragm level immediately above the story.

For a story with a flexible diaphragm immediately above,  $r_{max_i}$  shall be permitted to be calculated from an analysis that assumes rigid diaphragm behavior and  $\rho$  need not exceed 1.25.

The value,  $\rho$ , shall not be less than 1.0, and need not exceed 1.5.

Calculation of  $r_{max_i}$  need not consider the effects of accidental torsion and any dynamic amplification of torsion required by Section 9.5.5.5.2 of ASCE 7.

For structures with seismic-force-resisting systems in any direction comprised solely of special moment frames, the seismic-force-resisting system shall be configured such that the value of  $\rho$  calculated in accordance with this section does not exceed 1.25 for structures assigned to Seismic Design Category D, and does not exceed 1.1 for structures assigned to Seismic Design Category E or F.

**Exception:** The calculated value of  $\rho$  is permitted to exceed these limits when the design story drift,  $\Delta$ , as determined in Section 1617.5.4, does not exceed  $\Delta_a/\rho$  for any story where  $\Delta_a$  is the allowable story drift from Table 1617.3.1.

The value  $\rho$  shall be permitted to be taken equal to 1.0 in the following circumstances:

1. When calculating displacements for dynamic amplification of torsion in Section 9.5.5.5.2 of ASCE 7.
2. When calculating deflections, drifts and seismic shear forces related to Sections 9.5.5.7.1 and 9.5.5.7.2 of ASCE 7.
3. For design calculations required by Section 1620, 1621 or 1622.

For structures with vertical combinations of seismic-force-resisting systems, the value,  $\rho$ , shall be determined independently for each seismic-force-resisting system. The redundancy coefficient of the lower portion shall not be less than the following:

$$\rho_L = \frac{R_L \rho_u}{R_u} \tag{Equation 16-55}$$

where:

$\rho_L$  =  $\rho$  of lower portion.

$R_L$  =  $R$  of lower portion.

$\rho_u$  =  $\rho$  of upper portion.

$R_u$  =  $R$  of upper portion.

**1617.3 Deflection and drift limits.** The provisions given in Section 9.5.2.8 of ASCE 7 shall be used.

**Exception:** Structures designed using the simplified analysis procedure in Section 1617.5 shall meet the provisions in Section 1617.3.1.

**1617.3.1 Deflection and drift limits (for use in the simplified analysis procedure of Section 1617.5).** The design story drift,  $\Delta$ , as determined in Section 1617.5.4, shall not exceed the allowable story drift,  $\Delta_a$ , as obtained from Table 1617.3.1 for any story. All portions of the building shall be designed to act as an integral unit in resisting seismic forces unless separated structurally by a distance sufficient to avoid damaging contact under total deflection as determined in Section 1617.5.4. Buildings shall not exceed the limitations of Section 1616.6.1.

**1617.4 Equivalent lateral force procedure for seismic design of buildings.** The provisions given in Section 9.5.5 of ASCE 7 shall be used.

**1617.5 Simplified analysis procedure for seismic design of buildings.** See Section 1616.6.1 for limitations on the use of this procedure. For purposes of this analytical procedure, a building is considered to be fixed at the base.

**1617.5.1 Seismic base shear.** The seismic base shear,  $V$ , in a given direction shall be determined in accordance with the following equation:

$$V = \frac{1.2 S_{DS}}{R} W \tag{Equation 16-56}$$

where:

$S_{DS}$  = The design elastic response acceleration at short period as determined in accordance with Section 1615.1.3.

$R$  = The response modification factor from Table 1617.6.2.

$W$  = The effective seismic weight of the structure, including the total dead load and other loads listed below:

1. In areas used for storage, a minimum of 25 percent of the reduced floor live load (floor live load in public garages and open parking structures need not be included).
2. Where an allowance for partition load is included in the floor load design, the actual partition weight or a minimum weight of 10 psf of floor area, whichever is greater (0.48 kN/m<sup>2</sup>).
3. Total weight of permanent operating equipment.
4. 20 percent of flat roof snow load where flat snow load exceeds 30 psf (1.44 kN/m<sup>2</sup>).



TABLE 1617.3.1  
ALLOWABLE STORY DRIFT,  $\Delta_a^a$

BUILDING	SEISMIC USE GROUP		
	I	II	III
Buildings, other than masonry shear wall or masonry wall frame buildings, four stories or less in height with interior walls, partitions, ceilings and exterior wall systems that have been designed to accommodate the story drifts	0.025 $h_{sx}^b$	0.020 $h_{sx}$	0.015 $h_{sx}$
Masonry cantilever shear wall buildings <sup>c</sup>	0.010 $h_{sx}$	0.010 $h_{sx}$	0.010 $h_{sx}$
Other masonry shear wall buildings	0.007 $h_{sx}$	0.007 $h_{sx}$	0.007 $h_{sx}$
Masonry wall frame buildings	0.013 $h_{sx}$	0.013 $h_{sx}$	0.010 $h_{sx}$
All other buildings	0.020 $h_{sx}$	0.015 $h_{sx}$	0.010 $h_{sx}$

For SI: 1 inch = 25.4 mm.

- a. There shall be no drift limit for single-story buildings with interior walls, partitions, ceilings and exterior wall systems that have been designed to accommodate the story drifts.
- b.  $h_{sx}$  is the story height below Level  $x$ .
- c. Buildings in which the basic structural system consists of masonry shear walls designed as vertical elements cantilevered from their base or foundation support which are so constructed that moment transfer between shear walls (coupling) is negligible.

**1617.5.2 Vertical distribution.** The forces at each level shall be calculated using the following equation:

$$F_x = \frac{1.2 S_{DS}}{R} w_x \quad \text{(Equation 16-57)}$$

where:

$w_x$  = The portion of the effective seismic weight of the structure,  $W$ , at Level  $x$ .

**1617.5.3 Horizontal distribution.** Diaphragms constructed of untopped steel decking or wood structural panels or similar light-framed construction are permitted to be considered as flexible.

**1617.5.4 Design drift.** For the purposes of Sections 1617.3.1 and 1620.4.6, the design story drift,  $\Delta$ , shall be taken as 1 percent of the story height unless a more exact analysis is provided.

**1617.6 Seismic-force-resisting systems.** The provisions given in Section 9.5.2.2 of ASCE 7 shall be used except as modified in Section 1617.6.1.

**Exception:** For structures designed using the simplified analysis procedure in Section 1617.5, the provisions of Section 1617.6.2 shall be used.

**1617.6.1 Modifications to ASCE 7, Section 9.5.2.2.**

**1617.6.1.1 ASCE 7, Table 9.5.2.2.** Modify Table 9.5.2.2 as follows:

1. Bearing wall systems: Ordinary reinforced masonry shear walls shall use a response modification coefficient of  $2\frac{1}{2}$ . Light-framed walls sheathed with wood structural panels rated for shear resistance or steel sheets shall use a response modification coefficient of  $6\frac{1}{2}$ . Table 1617.6.2 entries for ordinary plain prestressed masonry shear walls, intermediate prestressed masonry shear walls and special prestressed masonry shear walls shall apply.
2. Building frame systems: Ordinary reinforced masonry shear walls shall use a response modifica-

tion coefficient of 3. Light-framed walls sheathed with wood structural panels rated for shear resistance or steel sheets shall use a response modification coefficient of 7. Table 1617.6.2 entries for ordinary plain prestressed masonry shear walls, intermediate prestressed masonry shear walls and special prestressed masonry shear walls shall apply.

3. Dual systems with intermediate moment frames capable of resisting at least 25 percent of prescribed seismic forces. Special steel concentrically braced frames shall use a deflection amplification factor of 4.
4. The table column titled Detailing Reference Section in Table 1617.6.2 shall apply.

**1617.6.1.2 ASCE 7, Section 9.5.2.2.2.1.** Modify Section 9.5.2.2.2.1 by adding Exception 3 as follows:

3. The following two-stage static analysis procedure is permitted to be used for structures having a flexible upper portion supported on a rigid lower portion where both portions of the structure considered separately can be classified as being regular, the average story stiffness of the lower portion is at least 10 times the average story stiffness of the upper portion and the period of the entire structure is not greater than 1.1 times the period of the upper portion considered as a separate structure fixed at the base:
  - 3.1. The flexible upper portion shall be designed as a separate structure using the appropriate values of  $R$  and  $\rho$ .
  - 3.2. The rigid lower portion shall be designed as a separate structure using the appropriate values of  $R$  and  $\rho$ . The reactions from the upper portion shall be those determined from the analysis of the upper portion amplified by the ratio of the  $R/\rho$  of the upper portion over  $R/\rho$  of the lower portion. This ratio shall not be less than 1.0.



**1617.6.1.3 ASCE 7, Section 9.5.2.2.4.3.** Modify Section 9.5.2.2.4.3 by changing exception to read as follows:

**Exception:** Reinforced concrete frame members not designed as part of the seismic-force-resisting system and slabs shall comply with Section 21.11 of Ref. 9.9-1.

**1617.6.2 Seismic-force-resisting systems (for use in the Simplified analysis procedure of Section 1617.5).** The basic lateral and vertical seismic-force-resisting systems shall conform to one of the types indicated in Table 1617.6.2 subject to the limitations on height indicated in the table based on seismic design category as determined in Section 1616. The appropriate response modification coefficient,  $R$ , system overstrength factor,  $\Omega_o$ , and deflection amplification factor,  $C_d$ , indicated in Table 1617.6.2 shall be used in determining the base shear, element design forces and design story drift. For seismic-force-resisting systems not listed in Table 1617.6.2, analytical and test data shall be submitted that establish the dynamic characteristics and demonstrate the lateral-force resistance and energy dissipation capacity to be equivalent to the structural systems listed in Table 1617.6.2 for equivalent response modification coefficient,  $R$ , system overstrength coefficient,  $\Omega_o$ , and deflection amplification factor,  $C_d$ , values. Buildings shall not exceed the limitations of Section 1616.6.1.

**Exception:** Structures assigned to Seismic Design Category A.

**1617.6.2.1 Dual systems.** For a dual system, the moment frame shall be capable of resisting at least 25 percent of the design forces. The total seismic force resistance is to be provided by the combination of the moment frame and the shear walls or braced frames in proportion to their stiffness.

**1617.6.2.2 Combination along the same axis.** For other than dual systems and shear wall-frame interactive systems, where a combination of different structural systems is utilized to resist lateral forces in the same direction, the value,  $R$ , used for design in that direction shall not be greater than the least value for any of the systems utilized in that same direction.

**Exception:** For light-framed, flexible diaphragm buildings, of Seismic Use Group I and two stories or less in height: Resisting elements are permitted to be designed using the least value of  $R$  for the different structural systems found on each independent line of resistance. The value of  $R$  used for design of diaphragms in such structures shall not be greater than the least value for any of the systems utilized in that same direction.

**1617.6.2.3 Combinations of framing systems.** Where different seismic-force-resisting systems are used along the two orthogonal axes of the structure, the appropriate response modification coefficient,  $R$ , system overstrength factor,  $\Omega_o$ , and deflection amplification factor,  $C_d$ , indicated in Table 1617.6.2 for each system shall be used.

**1617.6.2.3.1 Combination framing factor.** The response modification coefficient,  $R$ , in the direction under consideration at any story shall not exceed the lowest response modification coefficient,  $R$ , for the

seismic-force-resisting system in the same direction considered above that story, excluding penthouses. The system overstrength factor,  $\Omega_o$ , in the direction under consideration at any story, shall not be less than the largest value of this factor for the seismic-force-resisting system in the same direction considered above that story. In structures assigned to Seismic Design Category D, E or F, if a system with a response modification coefficient,  $R$ , with a value less than five is used as part of the seismic-force-resisting system in any direction of the structure, the lowest such value shall be used for the entire structure.

**Exceptions:**

1. Detached one- and two-family dwellings constructed of light framing.
2. The response modification coefficient,  $R$ , and system overstrength factor,  $\Omega_o$ , for supported structural systems with a weight equal to or less than 10 percent of the weight of the structure are permitted to be determined independent of the values of these parameters for the structure as a whole.
3. The following two-stage static analysis procedure is permitted to be used for structures having a flexible upper portion supported on a rigid lower portion where both portions of the structure considered separately can be classified as being regular, the average story stiffness of the lower portion is at least 10 times the average story stiffness of the upper portion and the period of the entire structure is not greater than 1.1 times the period of the upper portion considered as a separate structure fixed at the base:
  - 3.1. The flexible upper portion shall be designed as a separate structure using the appropriate values of  $R$  and  $\rho$ .
  - 3.2. The rigid lower portion shall be designed as a separate structure using the appropriate values of  $R$  and  $\rho$ . The reactions from the upper portion shall be those determined from the analysis of the upper portion amplified by the ratio of,  $R/\rho$ , of the upper portion over,  $R/\rho$ , of the lower portion. This ratio shall not be less than 1.0.

**1617.6.2.3.2 Combination framing detailing requirements.** The detailing requirements of Section 1620 required by the higher response modification coefficient,  $R$ , shall be used for structural components common to systems having different response modification coefficients.

**1617.6.2.4 System limitations for Seismic Design Category D, E or F.** In addition to the system limitation indicated in Table 1617.6.2, structures assigned to Seismic Design Category D, E or F shall be subject to the following.

TABLE 1617.6.2  
DESIGN COEFFICIENTS AND FACTORS FOR BASIC SEISMIC-FORCE-RESISTING SYSTEMS

BASIC SEISMIC-FORCE-RESISTING SYSTEM	DETAILING REFERENCE SECTION	RESPONSE MODIFICATION COEFFICIENT, <i>R</i> <sup>f</sup>	SYSTEM OVERSTRENGTH FACTOR, $\Omega_o$ <sup>g</sup>	DEFLECTION AMPLIFICATION FACTOR, <i>C<sub>d</sub></i> <sup>h</sup>	SYSTEM LIMITATIONS AND BUILDING HEIGHT LIMITATIONS (FEET) BY SEISMIC DESIGN CATEGORY AS DETERMINED IN SECTION 1616.3 <sup>c</sup>				
					A or B	C	D <sup>d</sup>	E <sup>e</sup>	F <sup>e</sup>
<b>1. Bearing Wall Systems</b>									
A. Ordinary steel braced frames in light-frame construction	2211	4	2	3 1/2	NL	NL	65	65	65
B. Special reinforced concrete shear walls	1910.2.4	5 1/2	2 1/2	5	NL	NL	160	160	100
C. Ordinary reinforced concrete shear walls	1910.2.3	4 1/2	2 1/2	4	NL	NL	NP	NP	NP
D. Detailed plain concrete shear walls	1910.2.2	2 1/2	2 1/2	2	NL	NP	NP	NP	NP
E. Ordinary plain concrete shear walls	1910.2.1	1 1/2	2 1/2	1 1/2	NL	NP	NP	NP	NP
F. Special reinforced masonry shear walls	1.13.2.2.5 <sup>o</sup>	5	2 1/2	3 1/2	NL	NL	160	160	100
G. Intermediate reinforced masonry shear walls	1.13.2.2.4 <sup>o</sup>	3 1/2	2 1/2	2 1/4	NL	NL	NP	NP	NP
H. Ordinary reinforced masonry shear walls	1.13.2.2.3 <sup>o</sup>	2 1/2	2 1/2	1 3/4	NL	160	NP	NP	NP
I. Detailed plain masonry shear walls	1.13.2.2.2 <sup>o</sup>	2	2 1/2	1 3/4	NL	NP	NP	NP	NP
J. Ordinary plain masonry shear walls	1.13.2.2.1 <sup>o</sup>	1 1/2	2 1/2	1 1/4	NL	NP	NP	NP	NP
K. Light frame walls with shear panels—wood structural panels/sheet steel panels	2306.4.1/2211	6 1/2	3	4	NL	NL	65	65	65
L. Light framed walls with shear panels—all other materials	2306.4.5/2211	2	2 1/2	2	NL	NL	35	NP	NP
M. Ordinary plain prestressed masonry shear walls	2106.1.1.1	1 1/2	2 1/2	1 1/4	NL	NP	NP	NP	NP
N. Intermediate prestressed masonry shear walls	2106.1.1.2, 1.13.2.2.4 <sup>o</sup>	2 1/2	2 1/2	2 1/2	NL	35	NP	NP	NP
O. Special prestressed masonry shear walls	2106.1.1.3, 1.13.2.2.5 <sup>o</sup>	4 1/2	2 1/2	3 1/2	NL	35	35	35	35
<b>2. Building Frame Systems</b>									
A. Steel eccentrically braced frames, moment-resisting, connections at columns away from links	(15) <sup>j</sup>	8	2	4	NL	NL	160	160	100
B. Steel eccentrically braced frames, nonmoment-resisting, connections at columns away from links	(15) <sup>j</sup>	7	2	4	NL	NL	160	160	100
C. Special steel concentrically braced frames	(13) <sup>j</sup>	6	2	5	NL	NL	160	160	100
D. Ordinary steel concentrically braced frames	(14) <sup>j</sup>	5	2	4 1/2	NL	NL	35 <sup>n</sup>	35 <sup>n</sup>	NP <sup>n</sup>
E. Special reinforced concrete shear walls	1910.2.4	6	2 1/2	5	NL	NL	160	160	100
F. Ordinary reinforced concrete shear walls	1910.2.3	5	2 1/2	4 1/2	NL	NL	NP	NP	NP
G. Detailed plain concrete shear walls	1910.2.2	3	2 1/2	2 1/2	NL	NP	NP	NP	NP

(continued)

TABLE 1617.6.2—continued  
DESIGN COEFFICIENTS AND FACTORS FOR BASIC SEISMIC-FORCE-RESISTING SYSTEMS

BASIC SEISMIC-FORCE-RESISTING SYSTEM	DETAILING REFERENCE SECTION	RESPONSE MODIFICATION COEFFICIENT, $R$	SYSTEM OVERSTRENGTH FACTOR, $\Omega_e^b$	DEFLECTION AMPLIFICATION FACTOR, $C_d^c$	SYSTEM LIMITATIONS AND BUILDING HEIGHT LIMITATIONS (FEET) BY SEISMIC DESIGN CATEGORY <sup>c</sup> AS DETERMINED IN SECTION 1616.3 <sup>f</sup>				
					A or B	C	D <sup>d</sup>	E <sup>e</sup>	F <sup>e</sup>
H. Ordinary plain concrete shear walls	1910.2.1	2	2 <sup>1/2</sup>	2	NL	NP	NP	NP	NP
I. Composite eccentrically braced frames	(14) <sup>k</sup>	8	2	4	NL	NL	160	160	100
J. Composite concentrically braced frames	(13) <sup>k</sup>	5	2	4 <sup>1/2</sup>	NL	NL	160	160	100
K. Ordinary composite braced frames	(12) <sup>k</sup>	3	2	3	NL	NL	NP	NP	NP
L. Composite steel plate shear walls	(17) <sup>k</sup>	6 <sup>1/2</sup>	2 <sup>1/2</sup>	5 <sup>1/2</sup>	NL	NL	160	160	100
M. Special composite reinforced concrete shear walls with steel elements	(16) <sup>k</sup>	6	2 <sup>1/2</sup>	5	NL	NL	160	160	100
N. Ordinary composite reinforced concrete shear walls with steel elements	(15) <sup>k</sup>	5	2 <sup>1/2</sup>	4 <sup>1/2</sup>	NL	NL	NP	NP	NP
O. Special reinforced masonry shear walls	1.13.2.2.5 <sup>o</sup>	5 <sup>1/2</sup>	2 <sup>1/2</sup>	4	NL	NL	160	160	100
P. Intermediate reinforced masonry shear walls	1.13.2.2.4 <sup>o</sup>	4	2 <sup>1/2</sup>	2 <sup>1/2</sup>	NL	NL	NP	NP	NP
Q. Ordinary reinforced masonry shear walls	1.13.2.2.3 <sup>o</sup>	3	2 <sup>1/2</sup>	2 <sup>1/4</sup>	NL	160	NP	NP	NP
R. Detailed plain masonry shear walls	1.13.2.2.2 <sup>o</sup>	2 <sup>1/2</sup>	2 <sup>1/2</sup>	2 <sup>1/4</sup>	NL	NP	NP	NP	NP
S. Ordinary plain masonry shear walls	1.13.2.2.1 <sup>o</sup>	1 <sup>1/2</sup>	2 <sup>1/2</sup>	1 <sup>1/4</sup>	NL	NP	NP	NP	NP
T. Light frame walls with shear panels—wood structural panels/sheet steel panels	2306.4.1/2211	7	2 <sup>1/2</sup>	4 <sup>1/2</sup>	NL	NL	65	65	65
U. Light framed walls with shear panels—all other materials	2306.4.5/2211	2 <sup>1/2</sup>	2 <sup>1/2</sup>	2 <sup>1/2</sup>	NL	NL	35	NP	NP
V. Ordinary plain prestressed masonry shear walls	2106.1.1.1	1 <sup>1/2</sup>	2 <sup>1/2</sup>	1 <sup>1/4</sup>	NL	NP	NP	NP	NP
W. Intermediate prestressed masonry shear walls	2106.1.1.2, 1.13.2.2.4 <sup>o</sup>	3	2 <sup>1/2</sup>	2 <sup>1/2</sup>	NL	35	NP	NP	NP
X. Special prestressed masonry shear walls	2106.1.1.3, 1.13.2.2.5 <sup>o</sup>	4 <sup>1/2</sup>	2 <sup>1/2</sup>	4	NL	35	35	35	35
<b>3. Moment-resisting Frame Systems</b>									
A. Special steel moment frames	(9) <sup>j</sup>	8	3	5 <sup>1/2</sup>	NL	NL	NL	NL	NL
B. Special steel truss moment frames	(12) <sup>j</sup>	7	3	5 <sup>1/2</sup>	NL	NL	160	100	NP
C. Intermediate steel moment frames	(10) <sup>j</sup>	4 <sup>1/2</sup>	3	4	NL	NL	35 <sup>h</sup>	NP <sup>h,i</sup>	NP <sup>h,i</sup>
D. Ordinary steel moment frames	(11) <sup>j</sup>	3 <sup>1/2</sup>	3	3	NL	NL	NP <sup>h,i</sup>	NP <sup>h,i</sup>	NP <sup>h,i</sup>
E. Special reinforced concrete moment frames	(21.1) <sup>l</sup>	8	3	5 <sup>1/2</sup>	NL	NL	NL	NL	NL

(continued)

TABLE 1617.6.2—continued  
DESIGN COEFFICIENTS AND FACTORS FOR BASIC SEISMIC-FORCE-RESISTING SYSTEMS

BASIC SEISMIC-FORCE-RESISTING SYSTEM	DETAILING REFERENCE SECTION	RESPONSE MODIFICATION COEFFICIENT, R <sup>a</sup>	SYSTEM OVERSTRENGTH FACTOR, Ω <sub>o</sub> <sup>b</sup>	DEFLECTION AMPLIFICATION FACTOR, C <sub>d</sub> <sup>b</sup>	SYSTEM LIMITATIONS AND BUILDING HEIGHT LIMITATIONS (FEET) BY SEISMIC DESIGN CATEGORY AS DETERMINED IN SECTION 1616.3 <sup>c</sup>				
					A or B	C	D <sup>d</sup>	E <sup>e</sup>	F <sup>e</sup>
F. Intermediate reinforced concrete moment frames	(21.1) <sup>f</sup>	5	3	4 1/2	NL	NL	NP	NP	NP
G. Ordinary reinforced concrete moment frames	(21.1) <sup>f</sup>	3	3	2 1/2	NL	NP	NP	NP	NP
H. Special composite moment frames	(9) <sup>k</sup>	8	3	5 1/2	NL	NL	NL	NL	NL
I. Intermediate composite moment frames	(10) <sup>k</sup>	5	3	4 1/2	NL	NP	NP	NP	NP
J. Composite partially restrained moment frames	(8) <sup>k</sup>	6	3	5 1/2	160	160	100	NP	NP
K. Ordinary composite moment frames	(11) <sup>k</sup>	3	3	2 1/2	NL	NP	NP	NP	NP
L. Masonry wall frames	2106	5 1/2	3	5	NL	NL	160	160	100
<b>4. Dual Systems with Special Moment Frames</b>									
A. Steel eccentrically braced frames, moment-resisting connections, at columns away from links	(15) <sup>j</sup>	8	2 1/2	4	NL	NL	NL	NL	NL
B. Steel eccentrically braced frames, nonmoment-resisting connections, at columns away from links	(15) <sup>j</sup>	7	2 1/2	4	NL	NL	NL	NL	NL
C. Special steel concentrically braced frames	(13) <sup>j</sup>	8	2 1/2	6 1/2	NL	NL	NL	NL	NL
D. Special reinforced concrete shear walls	1910.2.4	8	2 1/2	6 1/2	NL	NL	NL	NL	NL
E. Ordinary reinforced concrete shear walls	1910.2.3	7	2 1/2	6	NL	NL	NP	NP	NP
F. Composite eccentrically braced frames	(14) <sup>k</sup>	8	2 1/2	4	NL	NL	NL	NL	NL
G. Composite concentrically braced frames	(13) <sup>k</sup>	6	2 1/2	5	NL	NL	NL	NL	NL
H. Composite steel plate shear walls	(17) <sup>k</sup>	8	2 1/2	6 1/2	NL	NL	NL	NL	NL
I. Special composite reinforced concrete shear walls with steel elements	(16) <sup>k</sup>	8	2 1/2	6 1/2	NL	NL	NL	NL	NL
J. Ordinary composite reinforced concrete shear walls with steel elements	(15) <sup>k</sup>	7	2 1/2	6	NL	NL	NP	NP	NP
K. Special reinforced masonry shear walls	1.13.2.2.5 <sup>o</sup>	7	3	6 1/2	NL	NL	NL	NL	NL
L. Intermediate reinforced masonry shear walls	1.13.2.2.4 <sup>o</sup>	6 1/2	3	5 1/2	NL	NL	NP	NP	NP
<b>5. Dual Systems with Intermediate Moment Frames<sup>m</sup></b>									
A. Special steel concentrically braced frames <sup>f</sup>	(13) <sup>j</sup>	4 1/2	2 1/2	4	NL	NL	35 <sup>h</sup>	N <sup>ph,i</sup>	NP
B. Special reinforced concrete shear walls	1910.2.4	6	2 1/2	5	NL	NL	160	100	100
C. Ordinary reinforced concrete shear walls	1910.2.3	5 1/2	2 1/2	4 1/2	NL	NL	NP	NP	NP

(continued)



TABLE 1617.6.2—continued  
DESIGN COEFFICIENTS AND FACTORS FOR BASIC SEISMIC-FORCE-RESISTING SYSTEMS

BASIC SEISMIC-FORCE-RESISTING SYSTEM	DETAILING REFERENCE SECTION	RESPONSE MODIFICATION COEFFICIENT, $R^a$	SYSTEM OVERSTRENGTH FACTOR, $\Omega_o^b$	DEFLECTION AMPLIFICATION FACTOR, $C_d^c$	SYSTEM LIMITATIONS AND BUILDING HEIGHT LIMITATIONS (FEET) BY SEISMIC DESIGN CATEGORY AS DETERMINED IN SECTION 1616.3 <sup>d</sup>				
					A or B	C	D <sup>e</sup>	E <sup>e</sup>	F <sup>e</sup>
D. Ordinary reinforced masonry shear walls	1.13.2.2.3 <sup>o</sup>	3	3	2 1/2	NL	160	NP	NP	NP
E. Intermediate reinforced masonry shear walls	1.13.2.2.4 <sup>o</sup>	5	3	4 1/2	NL	NL	NP	NP	NP
F. Composite concentrically braced frames	(13) <sup>k</sup>	5	2 1/2	4 1/2	NL	NL	160	100	NP
G. Ordinary composite braced frames	(12) <sup>k</sup>	4	2 1/2	3	NL	NL	NP	NP	NP
H. Ordinary composite reinforced concrete shear walls with steel elements	(15) <sup>k</sup>	5 1/2	2 1/2	4 1/2	NL	NL	NP	NP	NP
<b>6. Shear Wall-frame Interactive System with Ordinary Reinforced Concrete Moment Frames and Ordinary Reinforced Concrete Shear Walls</b>	21.1 <sup>1</sup> 1910.2.3	5 1/2	2 1/2	5	NL	NP	NP	NP	NP
<b>7. Inverted Pendulum Systems</b>									
A. Cantilevered column systems		2 1/2	2	2 1/2	NL	NL	35	35	35
B. Special steel moment frames	(9) <sup>j</sup>	2 1/2	2	2 1/2	NL	NL	NL	NL	NL
C. Ordinary steel moment frames	(11) <sup>j</sup>	1 1/4	2	2 1/2	NL	NL	NP	NP	NP
D. Special reinforced concrete moment frames	21.1 <sup>1</sup>	2 1/2	2	1 1/4	NL	NL	NL	NL	NL
<b>8. Structural Steel Systems Not Specifically Detailed for Seismic Resistance</b>	AISC—335 AISC—LRFD AISI AISC—HSS	3	3	3	NL	NL	NP	NP	NP

For SI: 1 foot = 304.8 mm, 1 pound per square foot = 0.0479 KN/m<sup>2</sup>.

a. Response modification coefficient,  $R$ , for use throughout.

b. Deflection amplification factor,  $C_d$ .

c. NL = Not limited and NP = Not permitted.

d. See Section 1617.6.2.4.1 for a description of building systems limited to buildings with a height of 240 feet or less.

e. See Section 1617.6.2.4.1 for building systems limited to buildings with a height of 160 feet or less.

f. Ordinary moment frame is permitted to be used in lieu of intermediate moment frame in Seismic Design Categories B and C.

g. The tabulated value of the overstrength factor,  $\Omega_o$ , is permitted to be reduced by subtracting 1/2 for structures with flexible diaphragms but shall not be taken as less than 2.0 for any structure.

h. Steel ordinary moment frames and intermediate moment frames are permitted in single-story buildings up to a height of 60 feet, when the moment joints of field connections are constructed of bolted end plates and the dead load of the roof does not exceed 15 pounds per square foot. The dead weight of the portion of walls more than 35 feet above the base shall not exceed 15 pounds per square foot.

i. Steel ordinary moment frames are permitted in buildings up to a height of 35 feet, where the dead load of the walls, floors and roof does not exceed 15 pounds per square foot.

j. AISC 341 Part I or Part III section number.

k. AISC 341 Part II section number.

l. ACI 318, Section number.

m. Steel intermediate moment resisting frames as part of a dual system are not permitted in Seismic Design Categories D, E, and F.

n. Steel ordinary concentrically braced frames are permitted in penthouse structures and in single-story buildings up to a height of 60 feet when the dead load of the roof does not exceed 15 pounds per square foot.

o. ACI 530/ASCE 5/TMS 402 section number.

**1617.6.2.4.1 Limited building height.** For buildings that have steel-braced frames or concrete cast-in-place shear walls, the height limits in Table 1617.6.2 for Seismic Design Category D or E are increased to 240 feet (73 152 mm) and for Seismic Design Category F to 160 feet (48 768 mm) provided that the buildings are configured such that the braced frames or shear walls arranged in any one plane conform to the following:

1. The braced frames or shear walls in any one plane shall resist no more than 50 percent of the total seismic forces in each direction, neglecting torsional effects.
2. The seismic force in the braced frames or shear walls in any one plane resulting from torsional effects shall not exceed 20 percent of the total seismic force in the braced frames or shear walls.

**1617.6.2.4.2 Interaction effects.** Moment-resisting frames that are enclosed or adjoined by stiffer elements not considered to be part of the seismic-force-resisting system shall be designed so that the action or failure of those elements will not impair the vertical load and seismic-force-resisting capability of the frame. The design shall consider and provide for the effect of these rigid elements on the structural system at deformations corresponding to the design story drift,  $\Delta$ , as determined in Section 1617.5.4. In addition, the effects of these elements shall be considered when determining whether a structure has one or more of the irregularities defined in Section 1616.5.1.

**1617.6.2.4.3 Deformational compatibility.** Every structural component not included in the seismic-force-resisting system in the direction under consideration shall be designed to be adequate for vertical load-carrying capacity and the induced moments and shears resulting from the design story drift,  $\Delta$ , as determined in accordance with Section 1617.5.4. Where allowable stress design is used,  $\Delta$  shall be computed without dividing the earthquake force by 1.4. The moments and shears induced in components that are not included in the seismic-force-resisting system in the direction under consideration shall be calculated including the stiffening effects of adjoining rigid structural and nonstructural elements.

**Exception:** Reinforced concrete frame members not designed as part of the seismic-force-resisting system and slabs shall comply with Section 21.1.1 of ACI 318.

**1617.6.2.4.4 Special moment frames.** A special moment frame that is used but not required by Table 1617.6.2 is permitted to be discontinued and supported by a stiffer system with a lower response modification coefficient,  $R$ , provided the requirements of Sections 1620.2.3 and 1620.4.1 are met. Where a special moment frame is required by Table 1617.6.2, the frame shall be continuous to the foundation.

## SECTION 1618 DYNAMIC ANALYSIS PROCEDURE FOR THE SEISMIC DESIGN OF BUILDINGS

**1618.1 Dynamic analysis procedures.** The following dynamic analysis procedures are permitted to be used in lieu of the equivalent lateral force procedure of Section 1617.4:

1. Modal Response Spectral Analysis.
2. Linear Time-history Analysis.
3. Nonlinear Time-history Analysis.

The dynamic analysis procedures listed above shall be performed in accordance with the requirements of Sections 9.5.6, 9.5.7 and 9.5.8, respectively, of ASCE 7.

## SECTION 1619 EARTHQUAKE LOADS SOIL-STRUCTURE INTERACTION EFFECTS

**1619.1 Analysis procedure.** If soil-structure interaction is considered in the determination of seismic design forces and corresponding displacements in the structure, the procedure given in Section 9.5.9 of ASCE 7 shall be used.

## SECTION 1620 EARTHQUAKE LOADS—DESIGN, DETAILING REQUIREMENTS AND STRUCTURAL COMPONENT LOAD EFFECTS

**1620.1 Structural component design and detailing.** The design and detailing of the components of the seismic-force-resisting system shall comply with the requirements of Section 9.5.2.6 of ASCE 7 in addition to the nonseismic requirements of this code except as modified in Sections 1620.1.1, 1620.1.2 and 1620.1.3.

**Exception:** For structures designed using the simplified analysis procedure in Section 1617.5, the provisions of Sections 1620.2 through 1620.5 shall be used.

**1620.1.1 ASCE 7, Section 9.5.2.6.2.5.** Section 9.5.2.6.2.5 of ASCE 7 shall not apply.

**1620.1.2 ASCE 7, Section 9.5.2.6.2.11.** Modify ASCE 7, Section 9.5.2.6.2.11, to read as follows:

9.5.2.6.2.11 Elements supporting discontinuous walls or frames. Columns, beams, trusses or slabs supporting discontinuous walls or frames of structures and the connections of the discontinuous element to the supporting member having plan irregularity Type 4 of Table 9.5.2.3.2 or vertical irregularity Type 4 of Table 9.5.2.3.3 shall have the design strength to resist the maximum axial force that can develop in accordance with the special seismic loads of Section 9.5.2.7.1.

**Exceptions:**

1. The quantity  $E$  in Section 9.5.2.7.1 need not exceed the maximum force that can be transmitted to the element by the lateral-force-resisting system at yield.
2. Concrete slabs supporting light-framed walls.

**1620.1.3 ASCE 7, Section 9.5.2.6.3.** Modify ASCE 7, Section 9.5.2.6.3, to read as follows:

9.5.2.6.3 Seismic Design Category C. Structures assigned to Category C shall conform to the requirements of Section 9.5.2.6.2 for Category B and to the requirements of this section. Structures that have plan structural irregularity Type 1a or 1b of Table 9.5.2.3.2 along both principal plan axes, or plan structural irregularity Type 5 of Table 9.5.2.3.2, shall be analyzed for seismic forces in compliance with Section 9.5.2.5.2.2. When the square root of the sum of the squares method of combining directional effects is used, each term computed shall be assigned the sign that will yield the most conservative result.

The orthogonal combination procedure of Section 9.5.2.5.2.2, Item a, shall be required for any column or wall that forms part of two or more intersecting seismic-force-resisting systems and is subjected to axial load due to seismic forces acting along either principal plan axis equaling or exceeding 20 percent of the axial load design strength of the column or wall.

**1620.2 Structural component design and detailing (for use in the simplified analysis procedure of Section 1617.5).** The design and detailing of the components of the seismic-force-resisting system for structures designed using the simplified analysis procedure in Section 1617.5 shall comply with the requirements of Sections 1620.2 through 1620.5 in addition to the nonseismic requirements of this code. Buildings shall not exceed the limitations of Section 1616.6.1.

**Exception:** Structures assigned to Seismic Design Category A.

Structures assigned to Seismic Design Category B (see Section 1616) shall conform to Sections 1620.2.1 through 1620.2.10.

**1620.2.1 Second-order load effects.** Where  $\theta$  exceeds 0.10 as determined in Section 9.5.5.7.2 in ASCE 7, second-order load effects shall be included in the evaluation of component and connection strengths.

**1620.2.2 Openings.** Where openings occur in shear walls, diaphragms or other plate-type elements, reinforcement at the edges of the openings shall be designed to transfer the stresses into the structure. The edge reinforcement shall extend into the body of the wall or diaphragm a distance sufficient to develop the force in the reinforcement.

**1620.2.3 Discontinuities in vertical system.** Structures with a discontinuity in lateral capacity, vertical irregularity Type 5, as defined in Table 1616.5.1.2, shall not be over two stories or 30 feet (9144 mm) in height where the “weak” story has a calculated strength of less than 65 percent of the story above.

**Exception:** Where the “weak” story is capable of resisting a total seismic force equal to the overstrength factor,  $\Omega_o$ , as given in Table 1617.6.2, multiplied by the design force prescribed in Section 1617.5, the height limitation does not apply.

**1620.2.4 Connections.** All parts of the structure, except at separation joints, shall be interconnected and the connections shall be designed to resist the seismic force,  $F_p$ , induced by the parts being connected. Any smaller portion of the structure shall be tied to the remainder of the structure for the greater of:

$$F_p = 0.133 S_{DS} w_p \quad \text{(Equation 16-58)}$$

or

$$F_p = 0.05 w_p \quad \text{(Equation 16-59)}$$

where:

$S_{DS}$  = The design, 5-percent damped, spectral response acceleration at short periods as defined in Section 1615.

$w_p$  = The weight of the smaller portion.

A positive connection for resisting a horizontal force acting parallel to the member shall be provided for each beam, girder or truss to its support for a force not less than 5 percent of the dead plus live load reaction.

**1620.2.5 Diaphragms.** Permissible deflection shall be that deflection up to which the diaphragm and any attached distributing or resisting element will maintain its structural integrity under design load conditions, such that the resisting element will continue to support design loads without danger to occupants of the structure.

Floor and roof diaphragms shall be designed to resist  $F_p$  as follows:

$$F_p = 0.2 I_E S_{DS} w_p + V_{px} \quad \text{(Equation 16-60)}$$

where:

$F_p$  = The seismic force induced by the parts.

$I_E$  = Occupancy importance factor (Table 1604.5).

$S_{DS}$  = The short-period site design spectral response acceleration coefficient (Section 1615).

$w_p$  = The weight of the diaphragm and other elements of the structure attached to the diaphragm.

$V_{px}$  = The portion of the seismic shear force at the level of the diaphragm, required to be transferred to the components of the vertical seismic-force-resisting system because of the offsets or changes in stiffness of the vertical components above or below the diaphragm.

Diaphragms shall provide for both shear and bending stresses resulting from these forces. Diaphragms shall have ties or struts to distribute the wall anchorage forces into the diaphragm. Diaphragm connections shall be positive, mechanical or welded-type connections.

**1620.2.6 Collector elements.** Collector elements shall be provided that are capable of transferring the seismic forces originating in other portions of the structure to the element providing the resistance to those forces. Collector elements, splices and their connections to resisting elements shall have the design strength to resist the special load combinations of Section 1605.4.

**Exception:** In structures or portions thereof braced entirely by light-framed shear walls, collector elements, splices and connections to resisting elements need only have the strength to resist the load combinations of Section 1605.2 or 1605.3.

**1620.2.7 Bearing walls and shear walls.** Bearing walls and shear walls and their anchorage shall be designed for an out-of-plane force,  $F_p$ , that is the greater of 10 percent of the weight of the wall, or the quantity given by Equation 16-61:

$$F_p = 0.40 I_E S_{DS} w_w \quad \text{(Equation 16-61)}$$

where:

$I_E$  = Occupancy importance factor (Table 1604.5).

$S_{DS}$  = The short-period site design spectral response acceleration coefficient (Section 1615.1.3 or 1615.2.5).

$w_w$  = The weight of the wall.

In addition, concrete and masonry walls shall be anchored to the roof and floors and members that provide lateral support for the wall or that are supported by the wall. The anchorage shall provide a direct connection between the wall and the supporting construction capable of resisting the greater of the force,  $F_p$ , as given by Equation 16-61 or  $(400 S_{DS} I_E)$  pounds per linear foot of wall. For SI:  $5838 S_{DS} I_E$  N/m. Walls shall be designed to resist bending between anchors where the anchor spacing exceeds 4 feet (1219 mm). Parapets shall conform to the requirements of Section 9.6.2.2 of ASCE 7.

**1620.2.8 Inverted pendulum-type structures.** Supporting columns or piers of inverted pendulum-type structures shall be designed for the bending moment calculated at the base determined using the procedures given in Section 1617.4 and varying uniformly to a moment at the top equal to one-half the calculated bending moment at the base.

**1620.2.9 Elements supporting discontinuous walls or frames.** Columns or other elements subject to vertical reactions from discontinuous walls or frames of structures having plan irregularity Type 4 of Table 1616.5.1.1 or vertical irregularity Type 4 of Table 1616.5.1.2 shall have the design strength to resist special seismic load combinations of Section 1605.4. The connections from the discontinuous walls or frames to the supporting elements need not have the design strength to resist the special seismic load combinations of Section 1605.4.

**Exceptions:**

1. The quantity,  $E_m$ , in Section 1617.1.1.2 need not exceed the maximum force that can be transmitted to the element by the lateral-force-resisting system at yield.
2. Concrete slabs supporting light-framed walls.

**1620.2.10 Direction of seismic load.** The direction of application of seismic forces used in design shall be that which will produce the most critical load effect in each component. The requirement will be deemed satisfied if the design seismic forces are applied separately and independently in each of the two orthogonal directions.

**1620.3 Seismic Design Category C.** Structures assigned to Seismic Design Category C (see Section 1616) shall conform to the requirements of Section 1620.2 for Seismic Design Category B and to Sections 1620.3.1 through 1620.3.2.

**1620.3.1 Anchorage of concrete or masonry walls.** Concrete or masonry walls shall be anchored to floors and roofs and members that provide out-of-plane lateral support for the wall or that are supported by the wall. The anchorage shall provide a positive direct connection between the wall and floor or roof capable of resisting the horizontal forces specified in Equation 16-62 for structures with flexible diaphragms or in Section 9.6.1.3 of ASCE 7 (using  $a_p$  of 1.0 and  $R_p$  of 2.5) for structures with diaphragms that are not flexible.

$$F_p = 0.8 S_{DS} I_E w_w \quad \text{(Equation 16-62)}$$

where:

$F_p$  = The design force in the individual anchors.

$I_E$  = Occupancy importance factor in accordance with Section 1616.2.

$S_{DS}$  = The design earthquake spectral response acceleration at short period in accordance with Section 1615.1.3.

$w_w$  = The weight of the wall tributary to the anchor.

Diaphragms shall be provided with continuous ties or struts between diaphragm chords to distribute these anchorage forces into the diaphragms. Where added chords are used to form subdiaphragms, such chords shall transmit the anchorage forces to the main cross ties. The maximum length-to-width ratio of the structural subdiaphragm shall be  $2^{1/2}$  to 1. Connections and anchorages capable of resisting the prescribed forces shall be provided between the diaphragm and the attached components. Connections shall extend into the diaphragms a sufficient distance to develop the force transferred into the diaphragm.

The strength design forces for steel elements of the wall anchorage system shall be 1.4 times the force otherwise required by this section.

In wood diaphragms, the continuous ties shall be in addition to the diaphragm sheathing. Anchorage shall not be accomplished by use of toenails or nails subject to withdrawal, nor shall wood ledgers or framing be used in cross-grain bending or cross-grain tension. The diaphragm sheathing shall not be considered effective as providing the ties or struts required by this section.

In metal deck diaphragms, the metal deck shall not be used as the continuous ties required by this section in the direction perpendicular to the deck span.

Diaphragm-to-wall anchorage using embedded straps shall be attached to or hooked around the reinforcing steel or otherwise terminated so as to directly transfer force to the reinforcing steel.

**1620.3.2 Direction of seismic load.** For structures that have plan structural irregularity Type 1a or 1b of Table 1616.5.1.1 along both principal plan axes, or plan structural irregularity Type 5 in Table 1616.5.1.1, the critical direction requirement



of Section 1620.2.10 shall be deemed satisfied if components and their foundations are designed for the following orthogonal combination of prescribed loads.

One hundred percent of the forces for one direction plus 30 percent of the forces for the perpendicular direction. The combination requiring the maximum component strength shall be used. Alternatively, the effects of the two orthogonal directions are permitted to be combined on a square root of the sum of the squares (SRSS) basis. When the SRSS method of combining directional effects is used, each term computed shall be assigned the sign that will result in the most conservative result.

The orthogonal combination procedure above shall be required for any column or wall that forms part of two or more intersecting seismic-force-resisting systems and is subjected to axial load due to seismic forces acting along either principal plan axis equaling or exceeding 20 percent of the axial load design strength of the column or wall.

**1620.4 Seismic Design Category D.** Structures assigned to Seismic Design Category D shall conform to the requirements of Section 1620.3 for Seismic Design Category C and to Sections 1620.4.1 through 1620.4.6.

**1620.4.1 Plan or vertical irregularities.** For buildings having a plan structural irregularity of Type 1a, 1b, 2, 3 or 4 in Table 1616.5.1.1 or a vertical structural irregularity of Type 4 in Table 1616.5.1.2, the design forces determined from Section 1617.5 shall be increased 25 percent for connections of diaphragms to vertical elements and to collectors, and for connections of collectors to the vertical elements.

**Exception:** When connection design forces are determined using the special seismic load combinations of Section 1605.4

**1620.4.2 Vertical seismic forces.** In addition to the applicable load combinations of Section 1605, horizontal cantilever and horizontal prestressed components shall be designed to resist a minimum net upward force of 0.2 times the dead load.

**1620.4.3 Diaphragms.** Floor and roof diaphragms shall be designed to resist design seismic forces determined in accordance with Equation 16-63 as follows:

$$F_{px} = \frac{\sum_{i=x}^n F_i}{\sum_{i=x}^n w_i} w_{px} \quad \text{(Equation 16-63)}$$

where:

- $F_i$  = The design force applied to Level  $i$ .
- $F_{px}$  = The diaphragm design force.
- $w_i$  = The weight tributary to Level  $i$ .
- $w_{px}$  = The weight tributary to the diaphragm at Level  $x$ .

The force determined from Equation 16-63 need not exceed  $0.4S_{DS}I_Ew_{px}$  but shall not be less than  $0.2S_{DS}I_Ew_{px}$  where  $S_{DS}$  is the design spectral response acceleration at short pe-

riod determined in Section 1615.1.3 and  $I_E$  is the occupancy importance factor determined in Section 1616.2. When the diaphragm is required to transfer design seismic force from the vertical-resisting elements above the diaphragm to other vertical-resisting elements below the diaphragm due to offsets in the placement of the elements or to changes in relative lateral stiffness in the vertical elements, these forces shall be added to those determined from Equation 16-63 and to the upper and lower limits on that equation.

**1620.4.4 Collector elements.** Collector elements shall be provided that are capable of transferring the seismic forces originating in other portions of the structure to the element providing resistance to those forces.

Collector elements, splices and their connections to resisting elements shall resist the forces determined in accordance with Equation 16-63. In addition, collector elements, splices and their connections to resisting elements shall have the design strength to resist the earthquake loads as defined in the special load combinations of Section 1605.4.

**Exception:** In structures, or portions thereof, braced entirely by light-framed shear walls, collector elements, splices and their connections to resisting elements need only be designed to resist forces in accordance with Equation 16-63.

**1620.4.5 Building separations.** All structures shall be separated from adjoining structures. Separations shall allow for the displacement  $\delta_M$ . Adjacent buildings on the same property shall be separated by at least  $\delta_{MT}$  where

$$\delta_{MT} = \sqrt{(\delta_{M1})^2 + (\delta_{M2})^2} \quad \text{(Equation 16-64)}$$

and  $\delta_{M1}$  and  $\delta_{M2}$  are the displacements of the adjacent buildings.

When a structure adjoins a property line not common to a public way, that structure shall also be set back from the property line by at least the displacement,  $\delta_M$ , of that structure.

**Exception:** Smaller separations or property line setbacks shall be permitted when justified by rational analyses based on maximum expected ground motions.

**1620.4.6 Anchorage of concrete or masonry walls to flexible diaphragms.** In addition to the requirements of Section 1620.3.1, concrete and masonry walls shall be anchored to flexible diaphragms based on the following:

1. When elements of the wall anchorage system are not loaded concentrically or are not perpendicular to the wall, the system shall be designed to resist all components of the forces induced by the eccentricity.
2. When pilasters are present in the wall, the anchorage force at the pilasters shall be calculated considering the additional load transferred from the wall panels to the pilasters. The minimum anchorage at a floor or roof shall not be less than that specified in Item 1.

**1620.5 Seismic Design Category E or F.** Structures assigned to Seismic Design Category E or F (Section 1616) shall con-



form to the requirements of Section 1620.4 for Seismic Design Category D and to Section 1620.5.1.

**1620.5.1 Plan or vertical irregularities.** Structures having plan irregularity Type 1b of Table 1616.5.1.1 or vertical irregularities Type 1b or 5 of Table 1616.5.1.2 shall not be permitted.

## SECTION 1621 ARCHITECTURAL, MECHANICAL AND ELECTRICAL COMPONENT SEISMIC DESIGN REQUIREMENTS

**1621.1 Component design.** Architectural, mechanical, electrical and nonstructural systems, components and elements permanently attached to structures, including supporting structures and attachments (hereinafter referred to as “components”), and nonbuilding structures that are supported by other structures, shall meet the requirements of Section 9.6 of ASCE 7 except as modified in Sections 1621.1.1, 1621.1.2 and 1621.1.3, excluding Section 9.6.3.11.2, of ASCE 7, as amended in this section.

**1621.1.1 ASCE 7, Section 9.6.3.11.2:** Section 9.6.3.11.2 of ASCE 7 shall not apply.

**1621.1.2 ASCE 7, Section 9.6.2.8.1.** Modify ASCE 7, Section 9.6.2.8.1, to read as follows:

9.6.2.8.1 General. Partitions that are tied to the ceiling and all partitions greater than 6 feet (1829 mm) in height shall be laterally braced to the building structure. Such bracing shall be independent of any ceiling splay bracing. Bracing shall be spaced to limit horizontal deflection at the partition head to be compatible with ceiling deflection requirements as determined in Section 9.6.2.6 for suspended ceilings and Section 9.6.2.2 for other systems.

**Exception:** Partitions not taller than 9 feet (2743 mm) when the horizontal seismic load does not exceed 5 psf (0.240 kN/m<sup>2</sup>) required in Section 1607.13 of the *International Building Code*.

**1621.1.3 ASCE 7, Section 9.6.3.13.** Modify ASCE 7, Section 9.6.3.13, to read as follows:

9.6.3.13 Mechanical equipment, attachments and supports. Attachments and supports for mechanical equipment not covered in Sections 9.6.3.8 through 9.6.3.12 or Section 9.6.3.16 shall be designed to meet the force and displacement provisions of Section 9.6.1.3 and 9.6.1.4 and the additional provisions of this section. In addition to their attachments and supports, such mechanical equipment designated as having an  $I_p = 1.5$ , which contains hazardous or flammable materials in quantities that exceed the maximum allowable quantities for an open system listed in Section 307 of the *International Building Code*, shall, itself, be designed to meet the force and displacement provisions of Sections 9.6.1.3 and 9.6.1.4 and the additional provisions of this section. The seismic design of mechanical equipment, attachments and their supports shall include analysis of the following: the dynamic effects of the equipment, its contents and, when appropriate, its supports. The interaction between the

equipment and the supporting structures, including other mechanical and electrical equipment, shall also be considered.

**1621.1.4 ASCE 7, Section 9.6.2.6.** Modify ASCE 7, Section 9.6.2.6, to add the following exception:

**Exception:** Ceilings in buildings with an  $I_p$  equal to 1.0 located in Seismic Design Category C and less than three stories in height.

## SECTION 1622 NONBUILDING STRUCTURES SEISMIC DESIGN REQUIREMENTS

**1622.1 Nonbuilding structures.** The requirements of Section 9.14 of ASCE 7 shall apply to nonbuilding structures except as modified by Sections 1622.1.1, 1622.1.2 and 1622.1.3.

**1622.1.1 ASCE 7, Section 9.14.5.1.** Modify Section 9.14.5.1, Item 9, to read as follows:

9. Where an approved national standard provides a basis for the earthquake-resistant design of a particular type of nonbuilding structure covered by Section 9.14, such a standard shall not be used unless the following limitations are met:

1. The seismic force shall not be taken as less than 80 percent of that given by the remainder of Section 9.14.5.1.
2. The seismic ground acceleration, and seismic coefficient, shall be in conformance with the requirements of Sections 9.4.1 and 9.4.1.2.5, respectively.
3. The values for total lateral force and total base overturning moment used in design shall not be less than 80 percent of the base shear value and overturning moment, each adjusted for the effects of soil structure interaction that is obtained by using this standard.

**1622.1.2 ASCE 7, Section 9.14.7.2.1.** Modify Section 9.14.7.2.1 to read as follows:

9.14.7.2.1 General. This section applies to all earth-retaining walls. The applied seismic forces shall be determined in accordance with Section 9.7.5.1 with a geotechnical analysis prepared by a registered design professional.

The seismic use group shall be determined by the proximity of the retaining wall to other nonbuilding structures or buildings. If failure of the retaining wall would affect an adjacent structure, the seismic use group shall not be less than that of the adjacent structure, as determined in Section 9.1.3. Earth-retaining walls are permitted to be designed for seismic loads as either yielding or nonyielding walls. Cantilevered reinforced concrete retaining walls shall be assumed to be yielding walls and shall be designed as simple flexural wall elements.

**1622.1.3 ASCE 7, Section 9.14.7.9.** Add a new Section 9.14.7.9 to read as follows:

9.14.7.9 Buried structures. As used in this section, the term “buried structures” means subgrade structures such

as tanks, tunnels and pipes. Buried structures that are designated as Seismic Use Group II or III, as determined in Section 9.1.3, or are of such a size or length as to warrant special seismic design as determined by the registered design professional, shall be identified in the geotechnical report. Buried structures shall be designed to resist seismic lateral forces determined from a substantiated analysis using standards approved by the building official. Flexible couplings shall be provided for buried structures where changes in the support system, configurations or soil condition occur.

structured in accordance with the requirements of Section 9.13 of ASCE 7, except as modified in Section 1623.1.1.

**1623.1.1 ASCE 7, Section 9.13.6.2.3.** Modify ASCE 7, Section 9.13.6.2.3, to read as follows:

9.13.6.2.3 Fire resistance. Fire-resistance ratings for the isolation system shall comply with Section 714.7 of the *International Building Code*.

**SECTION 1624  
COASTAL HIGH-HAZARD AREAS  
AND OCEAN HIGH-HAZARD AREAS**

Construction in coastal high-hazard areas and ocean high-hazard areas shall comply with ASCE 24 and Table 1624.

**SECTION 1623  
SEISMICALLY ISOLATED STRUCTURES**

**1623.1 Design requirements.** Every seismically isolated structure and every portion thereof shall be designed and con-

**TABLE 1624  
CORROSION RESISTANCE  
(applies only to structures located in coastal high hazard areas and ocean hazard areas)**

EXPOSURE LEVEL	OPEN (exterior, porches and underhouse)	VENTED/ENCLOSED (attic, floor trusses and enclosed)	CONDITIONED (heated/cooled living areas)
Nails, staples, screws	Hot dipped galvanized	Hot dipped galvanized	—
Nuts, bolts, washers, tie rods	Hot dipped galvanized	Hot dipped galvanized	—
Steel connection plates and straps ( $\frac{3}{16}$ " minimum thickness)	Hot dipped galvanized after fabrication	Hot dipped galvanized	—
Sheet metal connectors, wind anchors, joists, hangers, steel joists and beams	Stainless steel or hot dipped galvanized after fabrication	Hot dipped galvanized after plate fabrication	Hot dipped galvanized
Truss plates	Stainless steel or hot dipped galvanized after fabrication	Hot dipped galvanized after fabrication or stainless steel within 6'-0" of a gable louver or soffit vent. Otherwise in accordance with TPI 1-95 of the Truss Plate Institute	Standard galvanized

For SI: 1 inch = 25.4 mm, 1 foot = 304.8 mm.

